

LUBEMINDER PRODUCT GUIDE

02	PRODUCT INFORMATION
03	FAQ
04	HOW IT WORKS
05	PARTS & ORDERING INFORMATION
08	HYDRAULIC INSTALLATION GUIDE
10	PNEUMATIC INSTALLATION GUIDE
12	TROUBLESHOOTING GUIDE



LUBEMINDER
OIL & GREASE SYSTEMS

Automatic Chain Oiler

LUBEMINDER® AUTOMATIC OILING SYSTEMS

The LubeMinder® Automatic Oiler lubricates chains and sprockets to eliminate having to manually maintain equipment during critical harvest periods. The fully adjustable pump can automatically oil up to 8 chains and sprockets (pneumatic driven) or 10 chains and sprockets (hydraulic driven) and requires no electricity (hydraulic driven). Oil is pumped to the system's brushes, which clean debris off equipment chains and disperse the oil to pin bushing joints.

The LubeMinder® applies oil while the chain is warm and running, consistently oiling to minimize metal-to-metal contact and cool equipment parts.

FACTS & FEATURES

- **Increase Chain Life by 3x:** Specifically engineered brushes clean chains and sprockets while applying oil to all moving parts, increasing equipment life.
- **Climate Control:** Fully adjustable pump allows modification of dispensing rate and assures that all chains and sprockets are properly oiled regardless of climate or condition.
- **Eliminate Downtime:** Lubricating while parts are warm and running allows oil to penetrate pin bushing joints.
- **Increases Resale Value:** Machinery that is well maintained and fully equipped retains higher value for resale.
- **Save Money on Chain Replacement:** Longer lasting chains means less downtime and lower costs associated with chain replacement.
- **Requires No Electricity (hydraulic):** The LubeMinder hydraulic driven oiling system borrows the pilot signal from the hydraulic system, dispersing oil everytime the cylinder actuates.
- **Expand & Customize:** Spare parts & kits are available for system expansion and customization. Add more lines onto the pump for additional attachments with the "Add a Line Kit". The "Restrictor Kit" is used to limit oil dispersion on specific lines.
- **Pneumatically Operated (pneumatic):** The Pneumatic LubeMinder with electronic timer/controller uses a compressed air signal for applications where no hydraulic pilot signal is available.



Q&A ABOUT LUBEMINDER AUTOMATIC OILER

Why is it necessary to oil my chains and sprockets?

You should consistently lubricate your chain drives for six important reasons.

1. To resist friction and wear between moving parts.
2. Eliminate daily maintenance of chains and sprockets. *Increase life of your chains by 3x
3. Oil chains and sprockets automatically when they are warm and running.
4. Decrease downtime while increasing operational profits; chain breakage only happens when you are operating.
5. Increase fuel economy, better lubrication means less resistance.
6. Convenience, you never have to leave your cab to oil your chains and sprockets.

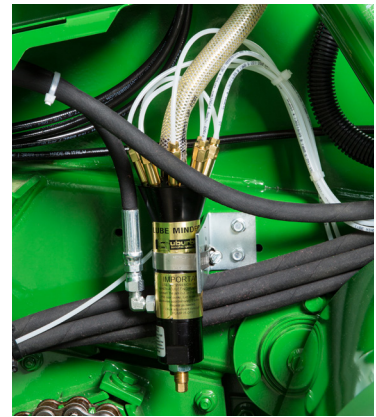

How can the LubeMinder® Automatic Oiler increase the life of my chains and sprockets?

The LubeMinder® applies oil when the chain is warm and running. This is the best time to apply lubricant because you get the proper penetration. Consistent oiling minimizes metal-to-metal contact and provides cooling. Oil pumped to a brush located next to the chain maximizes the amount of debris cleaned off the chain while it disperses the oil to the pin bushing joint to help eliminate chain stretch.

Is the Lube Minder® Automatic Oiler adjustable?

YES. Simply turning the brass adjusting screw will modify the oil dispensing rate to fit your specific operating conditions.

How long does a full reservoir last?

On average, the two-quart reservoir will last approximately 8 hours. This rate will vary by the way you adjust the pumps dispensing rate and the number of cycles your equipment uses.

What does a LubeMinder® Automatic Oiler kit contain?

The LubeMinder® has all the parts needed to install on round balers, combines, mower-conditioners, shredder attachments and other equipment. Even the drill bit to drill the correctly-sized holes comes in the kit. All you add is your own tools. You also need to purchase two quarts of the appropriate SAE chain oil for your conditions. (See section below on recommended oils.)

What type of oil should I use?

The type of oil is as important as the method of application. Most chain manufacturers recommend a good grade of clean petroleum chain oil without additives. Additives generally leave a varnish or gum residue which prevents oil from penetrating the chain joints. The highest viscosity oils flow best between the chain link plates, filling the pin-bushing areas, providing the best wear life. The following table identifies lubricant viscosity recommended for various temperatures.

20-40 F SAE20	40-100 F SAE30	100-120 F SAE40	120-140 F SAE50
---------------	----------------	-----------------	-----------------

How does the LubeMinder® Automatic Oiler cycle?

LubeMinder® Hydraulic Oiler cycles by tying into any double-acting hydraulic cylinder on your equipment. For example, on a round baler, use the cylinder which opens and closes the tailgate. On a mower-conditioner, use the cylinder which raises and lowers the cutting head. On a combine, you would use the cylinder which swings the unloader auger back and forth. LubeMinder® Pneumatic Oiler cycles by utilizing a pneumatic pilot signal and is controlled by a timer. The timer/controller requires 60+ PSI to actuate.

Does the LubeMinder® Automatic Oiler use hydraulic fluid?

It uses hydraulic fluid only to actuate the LubeMinder® pump within a closed system. The Pneumatic LubeMinder Kit does not require hydraulic fluid to actuate and instead requires a pneumatic pilot signal.

HOW DOES THE LUBEMINDER® WORK?

The **LubeMinder®** Automatic Oiler operates off an intermittent hydraulic or pneumatic signal. The hydraulic pilot signal hose can be connected to a cylinder, valve block, or manifold that does not trap pressure.

The **LubeMinder®** Automatic Oiler is cycled when it receives the pilot signal. The hydraulic pressure pushes the piston up, sending oil out to the brushes, dispensing a light film of oil to the chains and sprocket. For the pneumatic oiler, a pilot signal is pulled from an air compressor and pulsed using a timer controller.



The amount of oil dispensed per cycle is easily adjustable by turning the brass plunger in or out. Adjusting the plunger in, reduces the amount of oil sent to the brushes per cycle. Adjusting the plunger out, increases the oil to the brushes.

Below is a typical installation on a round baler. The hydraulic driven LubeMinder® Automatic Oiler is spliced into the line that runs to the rear gate lift cylinder. Each time the rear gate is cycled, your chains and sprockets are lubricated.

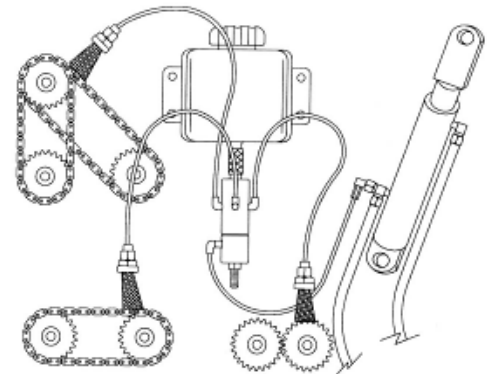
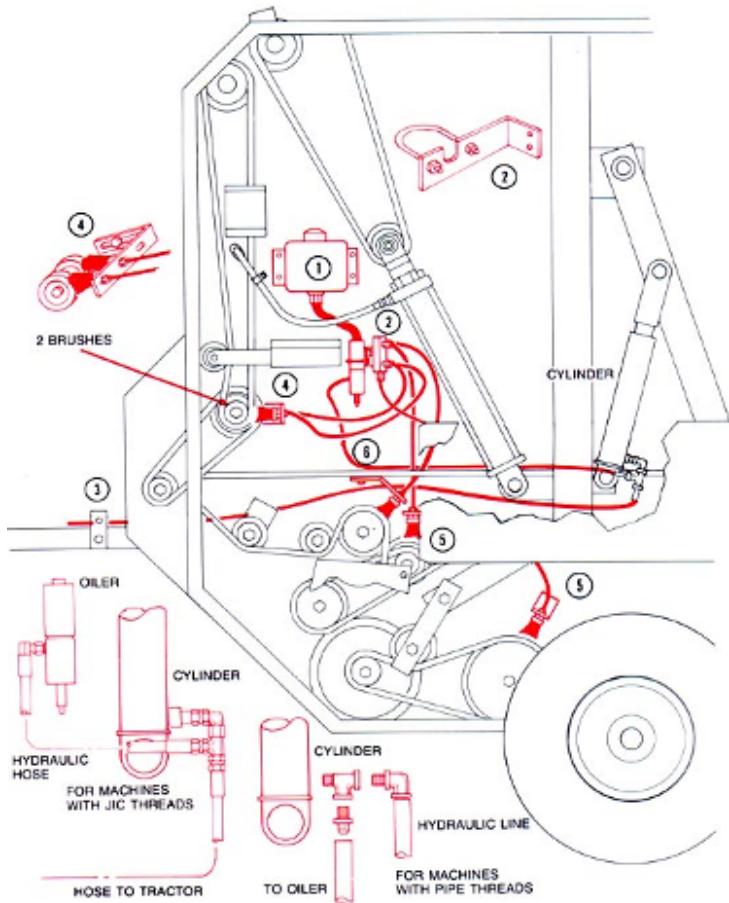
1. Oil reservoir tank is bolted to the sheet metal of the baler.
2. LubeMinder® Automatic Oiler pump feeds oil to the individual brushes.
3. Hydraulic pilot signal from the tractor actuates oiler pump.
4. Brush lubricating the main drive chains.
5. Brush lubricating the bale rolling chains.
6. Hydraulic line leading from the cylinder to the LubeMinder® Automatic Oiler pump.



WHAT'S INCLUDED IN THE LUBEMINDER® AUTOMATIC OILER KIT?

1-4 BRUSH UNIVERSAL KIT	5-8 BRUSH UNIVERSAL KIT	PNEUMATIC 110 VAC TIMER KIT
		
<p>170-0624</p> <p>Includes:</p> <ul style="list-style-type: none"> (1) 8 Port Pump (4) Manifold Valve Holder (4) Brush (1) Oil Reservoir Filter Screen (3) Bracket - 90° Long (2) Bracket - Flat Long (1) Bracket - 90° Short (2) Bracket - Flat Blank (1) Bracket - Oiler Pump Mounting (7) 1/8" NPT Plug (1) 2 Quart Reservoir Tank (5) Manifold Ferrule (5) Sleeve Nut (1) Restrictor Elbow (1) (5') 5/8" ID Pump Tubing (1) Universal LubeMinder Hardware Kit (10) (1') 1/4" Black Poly Tubing (2) 50' Nylon Brush Tubing 	<p>170-0628</p> <p>Includes:</p> <ul style="list-style-type: none"> (1) 8 Port Pump (8) Manifold Valve Holder (8) Brush (1) Oil Reservoir Filter Screen (6) Bracket - 90° Long (4) Bracket - Flat Long (2) Bracket - 90° Short (4) Bracket - Flat Blank (1) Bracket - Oiler Pump Mounting (3) 1/8" NPT Plug (1) 2 Quart Reservoir Tank (9) Manifold Ferrule (9) Sleeve Nut (1) Restrictor Elbow (1) (5') 5/8" ID Pump Tubing (1) Universal LubeMinder Hardware Kit (10) (1') 1/4" Black Poly Tubing (2) 50' Nylon Brush Tubing 	<p>170-0701</p> <p>Includes:</p> <ul style="list-style-type: none"> (1) 8 Port Pump (8) Manifold Valve Holder (8) Brush (1) Oil Reservoir Filter Screen (6) Bracket - 90° Long (4) Bracket - Flat Long (2) Bracket - 90° Short (4) Bracket - Flat Blank (1) Bracket - Oiler Pump Mounting (3) 1/8" NPT Plug (1) 2 Quart Reservoir Tank (9) Manifold Ferrule (9) Sleeve Nut (1) Controller / Timer 110v (1) (5') 5/8" ID Pump Tubing (1) Universal LubeMinder Hardware Kit (10) (1') 1/4" Black Poly Tubing (2) 50' Nylon Brush Tubing

For CNH, John Deere, Vermeer, & AGCO please contact your distributor for information about your LubeMinder Automatic Oiler Kit.

AUTOMATIC OILER KITS

OILER KITS - More parts listed on the website	PART NO.
GENERIC OILER KIT 1-4 Brush Universal Kit (hydraulic line not included)	170-0624
GENERIC OILER KIT 5-8 Brush Universal Kit (hydraulic line not included)	170-0628
PNEUMATIC 110 VAC TIMER KIT 5-8 Brush Universal Kit (pneumatic timer included)	170-0701
CNH KITS	
CNH COMBINE OILER KIT 230, 240 & 250 Series Combines (3-4 chains)	73342931
CNH COMBINE OILER KIT 130 & 140 Series Combines (4 chains)	73342932
CNH COMBINE OILER KIT 5088, 6088 & 7088 Axial Flow Series (4 chains)	73340218
CNH COMBINE OILER KIT AFX 7020, 7120, 8020, 8120, 9120 (3 chains)	87298214
CNH COMBINE OILER KIT CR Series (5 chains, 2014 and older)	87297646
CNH ROUND BALER OILER KIT RB, RBX, BR & BR-A (5-8 chains, 2014 and older)	73341081
CNH CASE RB BALER OILER KIT 465 & 565 MODELS (2015 and newer - less rotor cutter)	73344981
JOHN DEERE KITS	
JOHN DEERE Zero Series w/ Pre-Cutter, 5' & 6' Dia. Bales (7 chains)	170-0597
JOHN DEERE Zero-r, zero-M, and 9 Series; 6' diameter bales w/o pre-cutter (5 Chains)	170-0595
JOHN DEERE Zero Series; 450, 550, and 9 Series; 449, 459, 559 (5 Chains)	170-0594
JOHN DEERE 8 Series; 448, 458, 558 (5 Chains)	170-0580
JOHN DEERE 854, 582 Silage Special (10 Chains)	170-0578
JOHN DEERE Walker Combine 9400 (4 Chains)	170-0572
VERMEER KITS	
VERMEER 604N & 605N (7 Chains)	510561340
VERMEER 605 Super M, 604 Super M, 605M & 604M (7 Chains)	21999-0238
VERMEER 504 M (6 Chains)	21999-0338
VERMEER 505 & 504 M Classic, 5410 Rebel, 665 & 664 Rancher (5 Chains)	21999-0339
AGCO KITS	
AGCO 2800 Series (5 Chains)	21999-0530
AGCO 900, 5400 & 5500 Series (9 chains)	21999-0315
AGCO 7 Series, 447 - 567 (5 Chains)	79016658

SPARE PARTS & ACCESSORIES

MINI MAINTENANCE KIT	ADD A LINE / SPLICE KIT	LINE KIT WITH SHUTOFF	ORIFICE / RESTRICTOR KIT
			
<p>170-0607</p> <p>Includes:</p> <ul style="list-style-type: none"> (3) Brushes (12) Manifold Ferrules (4) Sleeve Nuts (2) Union Locks (1) (50') Nylon Brush Tubing (1) Reservoir Tank Cap 	<p>170-0600</p> <p>Includes:</p> <ul style="list-style-type: none"> 2) 5/32" Union Locks (2) 5/32" Union Tees (1) 50' Nylon Brush Tubing (8) Manifold Ferrules (4) Sleeve Nuts (1) Bracket - Short Angled (1) Bracket - Flat Blank (1) Bracket - 90° Long (1) Brush (1) 5/32" In Line Check Valve (5) Taptite Bolts for Brackets (3) Oiler Hose Clamps (1) Check Valve Manifold (10') 1/4" Black Poly Tubing 	<p>170-0601</p> <p>Includes:</p> <ul style="list-style-type: none"> (1) 1/8" Female Ball Valve (1) 1/8" NPT Hex Nipple (1) Check Valve Manifold (1) 5/32" Coupling Insert (1) 5/32" Coupling Body (1) Brush (1) 50' Nylon Brush Tubing (1) Bracket - Flat Blank (1) Bracket - Short Angled (1) Bracket - 90° Long (4) Taptite Bolts for Brackets (10') 1/4" Black Poly Tubing 	<p>170-0602</p> <p>Includes:</p> <ul style="list-style-type: none"> (5) Check Valve Manifolds (5) Orifices - Medium (5) Orifices - Small (10) Manifold Ferrules (5) Sleeve Nuts
BRUSH KIT	TANK ASSEMBLY KIT	LUBEMINDER PUMP (8)	LUBEMINDER PUMP (4)
			
<p>170-0604</p> <p>Includes:</p> <ul style="list-style-type: none"> (8) Brushes 	<p>170-0605</p> <p>Includes:</p> <ul style="list-style-type: none"> (1) 2 Quart Reservoir Tank (1) (3') 5/8" ID Pump Tubing (1) Oil Reservoir Filter Screen (2) 5/16" - 7/8" Hose Clamps (4) Taptite Bolts 	<p>170-0000</p> <p>Includes:</p> <ul style="list-style-type: none"> (1) 8 Port Pump 	<p>170-0000-4</p> <p>Includes:</p> <ul style="list-style-type: none"> (1) 8 Port Pump (4) Check Valve Manifolds

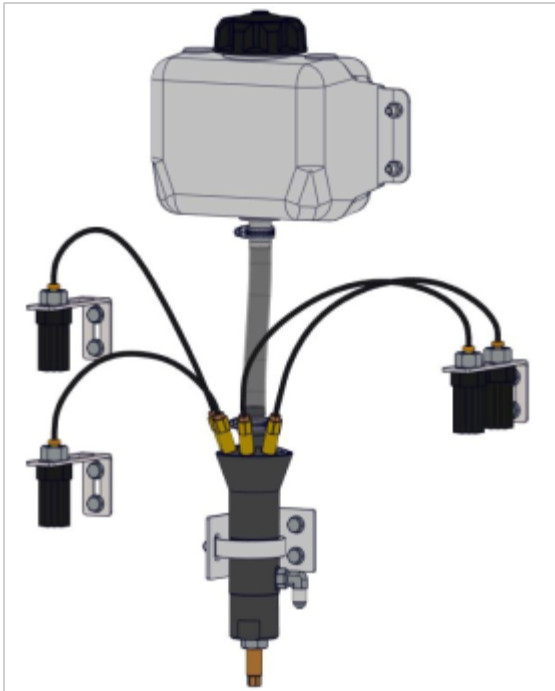

**Installation Instructions:
Universal LubeMinder® Kit**



Read all instructions carefully before beginning installation. Do not attempt to service any machine without exercising the mandatory safety shut down procedure as described in the operators manual. Installing this kit will require working near the tongue of a machine. Support the tongue following the OEM recommend procedure for service. Prevent the machine from moving by chocking the wheels. Make sure all hydraulic pressure is removed from the entire system. This includes all gates, cylinders, doors, booms, etc.

NOT INCLUDED

1. Hydraulic Hose: A hydraulic hose with one #4 JIC female end is required to run from the oiler pump to the equipment's hydraulic cylinder. See local dealer for information.
2. A tee to tie hydraulic line into pump.
3. 30 Weight Oil: LubeMinder® requires clean 30 weight oil. In colder conditions 10 weight oil may be used.

TOOLING REQUIRED

1. Drill
2. Adjustable or SAE Wrenches
3. Pliers
4. Flat Blade Screwdriver
5. 3 mm Hex Wrench
6. Drill Bit Set (Optional)

DESCRIPTION

The LubeMinder® automatic oiler provides a desired amount of oil to any chain or sprocket. **The system functions off of a 300psi or greater double acting hydraulic cylinder.** The pump actuates each time the equipment's hydraulic cylinder operates. This insures the machine is oiled in direct proportion to the number of cylinder cycles resulting in automatic hourly service per factory recommendation.

INSTALLATION

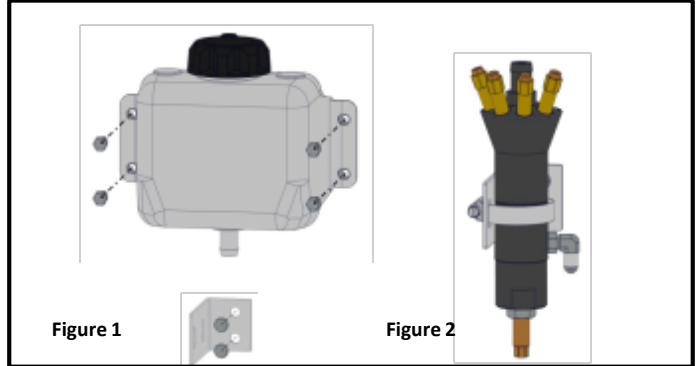

1. Mount the oil reservoir to side of machine closest to the double acting hydraulic cylinder. Using the tank as a template, mark and drill four 7/32" holes. Secure the tank with self tapping screws. See figure 1
2. Using self tapping screws, mount pump bracket approximately 1'-3' below the reservoir. Attach pump to bracket using provided hose clamp. Pump must be mounted in upright position. See figure 2
3. Cut the 5/8" ID hose as needed to connect oil reservoir to pump. Slide the two supplied hose clamps down the hose and secure one to each end of the pump and reservoir tank.
4. At this time, pour approximately 1/8 cup of clean 30 weight oil into the reservoir tank. This allows ample time for the oil to prime the pump and purge all of the air out. Note: Never use used engine oil
5. Once the entire installation is complete, finish filling reservoir tank.
6. Locate the hydraulic cylinder on the equipment. NOTE: The hydraulic cylinder in which the pump will tie in to must be double acting and reach a minimum pressure of 300psi. Disconnect the hydraulic fitting located on the RETURN side of the cylinder
7. Install Tee (not included) on RETURN side of hydraulic cylinder.
8. Route hydraulic line (not included) from hydraulic cylinder to LubeMinder®. Connect the end of the hose to #4 JIC fitting on side of LubeMinder® pump.

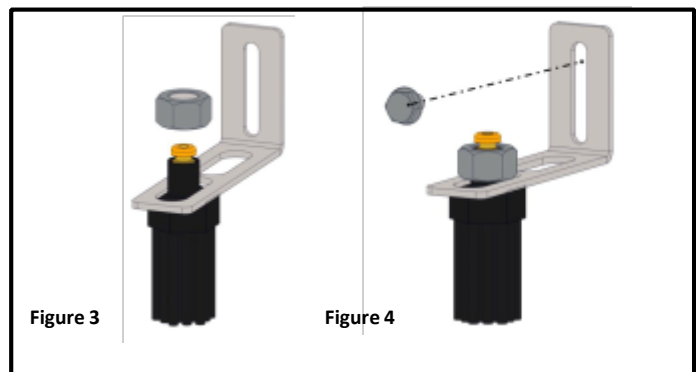

9. Install brushes on to the desired brackets using the 1/2"-20 nuts
10. (nuts should only be finger tight at this point as minor adjustment may be necessary). See figure 3
11. Place the brackets over the chain and on top of the sprocket. Using the bracket as a template, mark and drill one 7/32" holes. Secure the bracket with the self tapping screws. See figure 4
12. Adjust brackets so that the brushes are pressing down on the chain approximately 1/2". Snug up the 1/2" nuts on the brushes. Be sure not to overtighten nut as damage may occur to brush.
13. Repeat steps 10-12 for all brushes necessary.
14. Route oil lines. Use push-to-connect fitting on top of brush to secure tubing. Verify that the line is fully seated into the bottom of the push-to-connect fitting. Tubing can be removed from push-to-connect fitting by pressing downward on orange ring. See figure 5
15. NOTE: A small amount of 1/4" black tubing has been provided to use as a protective cover if needed around sharp or rough edges.

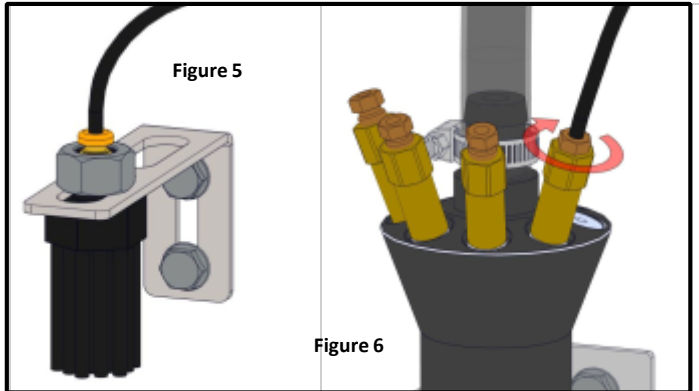
INSTALLATION cont.

13. Connect the 5/32" tubing into the manifold fitting located on the top of the oiler pump. Verify that the line is fully seated into the bottom of the manifold assembly. Cut and remove excess tubing.
14. Using a 5/16" wrench, snug the line into place by tightening brass fitting on the manifold assembly. See figure 6
15. Repeat steps 12-13 for the remaining oil lines

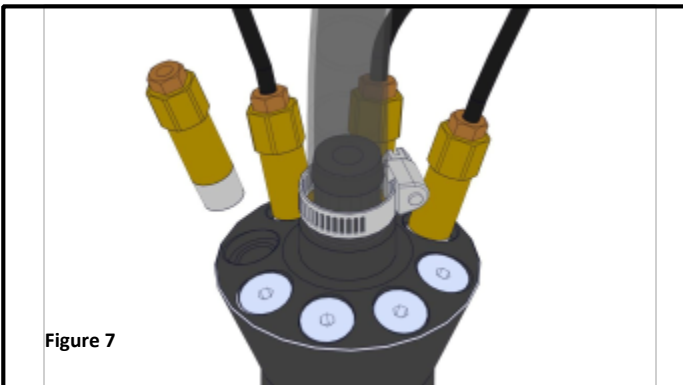

16. If less than four brushes are required, remove additional manifold assemblies using a 7/16" adjustable wrench.
17. If additional manifold assemblies are removed, use a 3 mm hex wrench to seal open pump port/s with provided plugs.
18. Verify that all brackets and fittings are tight. Replace and guards and shields that were removed during LubeMinder® installation.
19. Fill oil reservoir.
20. Cycle the cylinder in which the pump is connected to until oil can be seen in all brush lines. Once oil can be seen in the lines, top off reservoir tank with remaining oil. NOTE: Depending on the length of oil tubing used, 20-30 cycles may be necessary for initial oil to reach brushes.

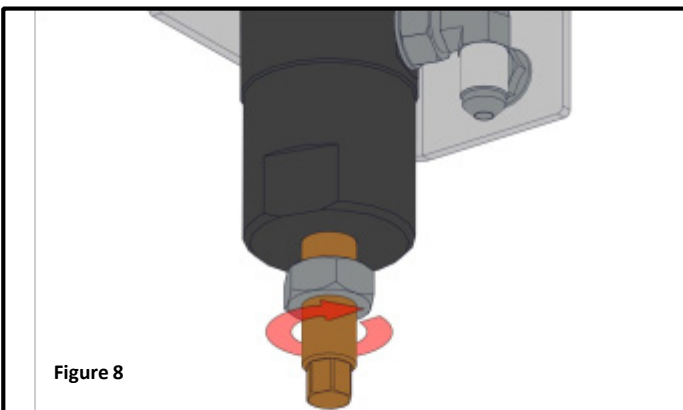

21. The LubeMinder® pump is factory set to deliver the maximum amount of oil per cycle. If less oil is desired, loosen the jam nut and turn in adjusting rod located on bottom of pump. If rod is turned completely in, pump is shut off.

FAQ'S**Why is it necessary to oil my chains and sprockets?**

1. To resist friction and wear between moving parts.
2. To flush away dirt and foreign material.
3. To lubricate chain-sprocket contact surfaces.
4. To retard rust and corrosion.
5. To carry heat away from bearings.
6. To cushion load impact areas of running parts.

I manually oil my chains everyday, why do I need LubeMinder®?

A chain assembly is a series of traveling metal bearings requiring proper lubrication for maximum performance. The lubrication forms a separating wedge between the pins and bushings in the chain joints—much like that formed in journal bearings. Oil applied manually to the rollers will not flow between the chain link plates and fill the critical pin bushing joints ultimately causing constant metal-to-metal contact and debris build-up. As a result of this build-up, chain elongation or "stretch" occurs. Metal wear and debris build-up cause a small distortion at the load area on every pin bushing. A #60 chain has 36 pin bushings per foot. Over a 15 foot length—that equals 540 potential distortion points.

This condition directly affects your equipment. As the chain gets longer—it rides too high on the sprocket and often the sprocket teeth begin to look like a wheat sickle. The affected sprockets can cause timing problems or chain and teeth breakage—resulting in downtime.

How can LubeMinder® increase the life of my equipment?

The LubeMinder® applies oil when the chain is warm and running. This is the best time to apply lubricant because you get the proper lubrication. Consistent oiling minimizes metal-to-metal contact and provides cooling. Oil pumped to a brush located next to the chain maximizes the amount of debris cleaned off the chain while it disperses the oil to the pin bushing joint to help eliminate chain stretch.

Is the LubeMinder® adjustable?

YES. We preset the LubeMinder® at the factory to deliver the maximum amount of oil, which is 0.5 oz (15 ml) per stroke. The Lube Minder® can adjusted all the way down to zero. This is done by simply turning the brass adjusting screw on the bottom of the pump. This will modify the oil dispensing rate to fit your specific operating conditions. See step 21

How long does a full reservoir last?

The LubeMinder® reservoir is designed to last for an entire day. The dispense rate can be varied by adjusting the pump.

What does a LubeMinder® kit contain?

The Universal LubeMinder® Kit is a generic system. You will need two quarts of 30 weight oil to fill the reservoir, a hydraulic hose for connecting the pump to the double acting hydraulic cylinder.

How long will it take to install a LubeMinder® on my equipment?

Most LubeMinder® installations average around 2-4 hours.

What type of oil should I use?

30 weight oil is the most common oil used. Most chain manufacturers recommend a good grade of clean petroleum chain oil without additives. Additives generally leave a varnish or gum residue which prevents oil from penetrating the chain joints. Never use engine oil.

How does the LubeMinder® cycle?

LubeMinder® pump cycles by tying into any double-acting hydraulic cylinder on your equipment. For example, on a combine, you would use the cylinder which swings the unloader auger back and forth. On a round baler, use the cylinder which opens and closes the tailgate. On a mower-conditioner, use the cylinder which raises and lowers the cutting head.

What pressure is required to cycle the LubeMinder® pump?

The most common LubeMinder® pump sold with kits for round balers and combines requires about 300 PSI (21 BAR).

Does the LubeMinder® consume hydraulic fluid?

No. The LubeMinder® does not consume hydraulic fluid. Hydraulic fluid is only required to actuate the pump.

INSTALLATION



Installation Instructions:

Pneumatic LubeMinder® Kit with 110 VAC Timer Controlled



WARNING

Read all instructions carefully before beginning installation. Do not attempt to service any machine without exercising the mandatory safety shut down procedure as described in the operators manual. Prevent the machine from moving by chocking the wheels. Make sure all hydraulic pressure is removed from the entire system. This includes all gates, cylinders, doors, booms, etc.

NOT INCLUDED

1. 30 Weight Oil: LubeMinder® requires clean 30 weight oil. In colder conditions 10 weight oil may be used.

TOOLING REQUIRED

1. Drill
2. Adjustable or SAE Wrenches
3. Pliers
4. Flat Blade Screwdriver
5. 3 mm Hex Wrench
6. Drill Bit Set (Optional)

DESCRIPTION

The LubeMinder® automatic oiler provides a desired amount of oil to any chain or sprocket. **The system functions off of 90 psi air and a 110v outlet .** The pump actuates when the timer powers the solenoid on the pneumatic valve and opens to let shop air into the piston housing on the LubeMinder®. This insures the machine is oiled automatically to the number of cycles hourly per factory recommendation.

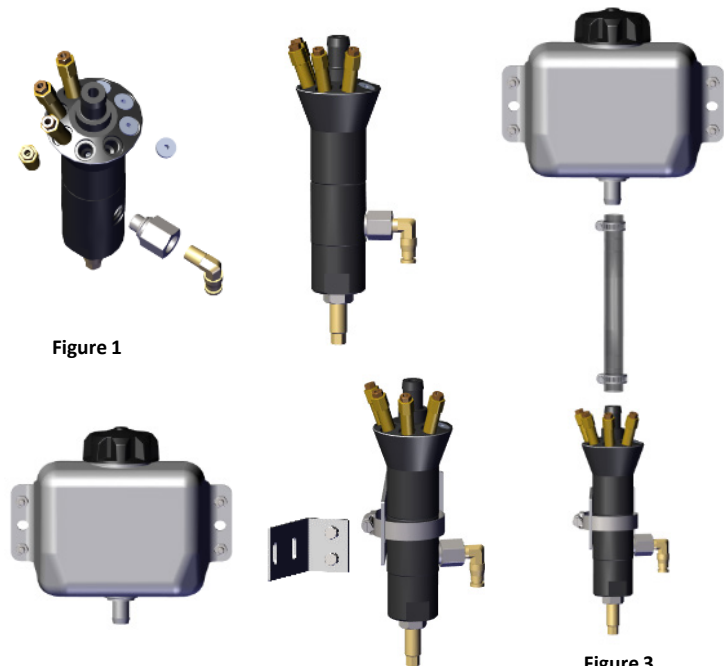

Figure 1

Figure 2

Figure 3

1. Install manifolds and plugs into LubeMinder®. Figure 1 (shown with 4 manifolds and plugs.) Use 7/16” wrench and 3mm hex driver.
2. Install fittings into LubeMinder® port. Figure 1
3. Mount the oil reservoir on a side of the machine with a convenient central location to the lubrication points if possible. Using the tank as a template, mark and drill four 7/32” holes. Secure the tank with self tapping screws. See figure 2
4. Using self tapping screws, mount pump bracket approximately 1’-3’ below the reservoir. Attach pump to bracket using provided hose clamp. Pump must be mounted in upright position. See figure 2
5. Cut the 5/8” ID hose as needed to connect oil reservoir to pump. Slide the two supplied hose clamps down the hose and secure one to each end of the pump and reservoir tank. See figure 3
6. At this time, pour approximately 1/8 cup of clean 30 weight oil into the reservoir tank. This allows ample time for the oil to prime the pump and purge all of the air out. Note: Never use used engine oil
7. Once the entire installation is complete, finish filling reservoir tank.

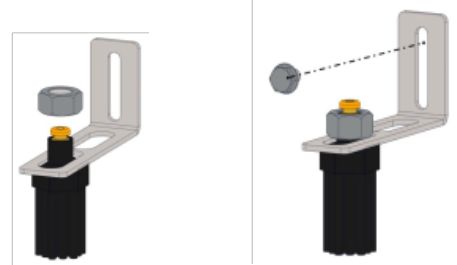
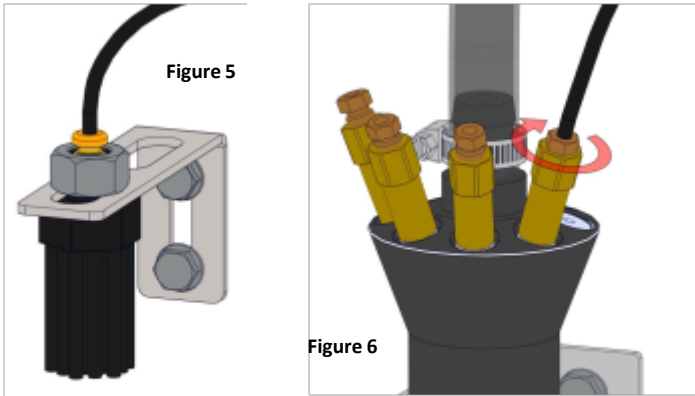

Figure 4

6. Install brushes on to the desired brackets using the 1/2-20 nuts (nuts should only be finger tight at this point as minor adjustment may be necessary). See figure 4
7. Place the brackets over the chain and on top of the sprocket. Using the bracket as a template, mark and drill one 7/32” holes. Secure the bracket with the self tapping screws. See figure 4
8. Adjust brackets so that the brushes are pressing down on the chain approximately 1/2”. Snug up the 1/2” nuts on the brushes. Be sure not to overtighten nut as damage may occur to brush.
9. Repeat steps 7-8 for all brushes necessary.
10. Route oil lines. Use push-to-connect fitting on top of brush to secure tubing. Verify that the line is fully seated into the bottom of the push-to-connect fitting. Tubing can be removed from push-to-connect fitting by pressing downward on orange ring. See figure 5
11. NOTE: A small amount of 1/4” black tubing has been provided to use as a protective cover if needed around sharp or rough edges.

INSTALLATION cont.



12. Connect the 5/32" tubing into the manifold fitting located on the top of the oiler pump. Verify that the line is fully seated into the bottom of the manifold assembly. Cut and remove excess tubing.
13. Using a 5/16" wrench, snug the line into place by tightening brass fitting on the manifold assembly. See figure 6
14. Repeat steps 12-13 for the remaining oil lines.

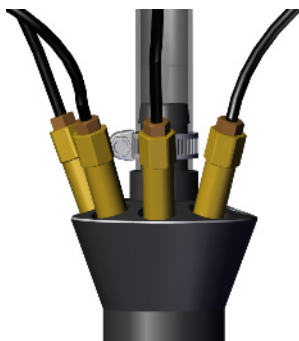

Figure 7

15. Verify that all brackets and fittings are tight.
16. Fill oil reservoir.

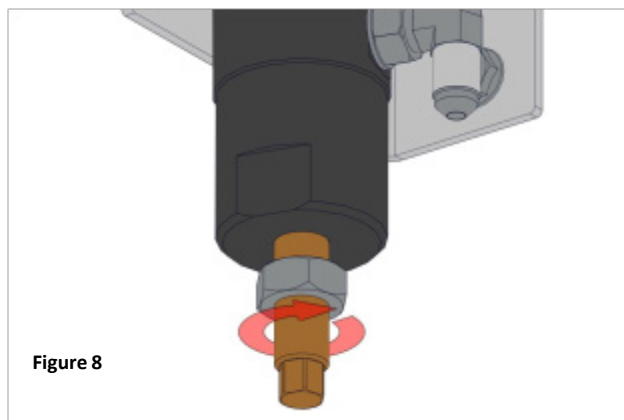

Figure 8

17. The LubeMinder® pump is factory set to deliver the maximum amount of oil per cycle. If less oil is desired, loosen the jam nut and turn in adjusting rod located on bottom of pump. If rod is turned completely in, pump is shut off.
18. Install air control valve.

Install Air Control Valve

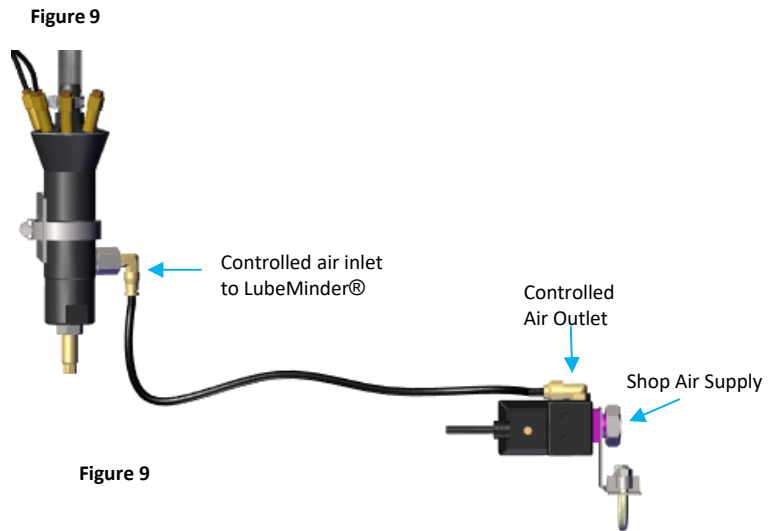

Figure 9

19. Install mounting bracket to air control valve.
20. Attach tubing from LubeMinder® to air control valve.
21. Set timer to desired on and off times. See figure 10

Set On time to 2-3 seconds



Figure 10

Set cycle time



Cut away of LubeMinder® pump

LUBEMINDER TROUBLESHOOTING GUIDE

Understanding the Pump



LUBEMINDER TROUBLESHOOTING GUIDE

SYMPTOM	CAUSE	SOLUTION
Oil not getting to brushes	1) Pump needs to be primed 2) Dirty oil was used or chaf was pulled in from reservoir 3) Pinched line 4) Orifice in hydraulic fitting 5) Brass plunger screwed all the way up, not allowing piston to retract	1) Follow priming pump instructions 2) Flush oil reservoir to remove chaf. Pump and manifolds will need to be cleaned to remove dirt or chaf 3) Trace all lines to verify no pinches 4) Verify tractor hydraulic pressure. If under 2000PSI, orifice is restricting flow to cycle pump 5) Adjust brass plunger out (counter clockwise), providing more flow
Oil dripping out of brushes when not in use	1) Manifold valve dirty, causing one-way valve (Schrader Valve) to stay open 2) One-way valve (Schrader Valve) loose	1) Remove manifold, apply light compressed air to blow out chaf Replace one-way valve Replace manifold 2) Tighten one-way valve 1/4 to 1/2 turn
Tubing blows out of manifold	Tubing not pushed into ferrule far enough	If ferrule is damaged or not installed properly, cut off 1/4" of tubing with ferrule, install new sleeve nut and ferrule. Tubing to stick out 1/4" beyond ferrule.
Tubing blows out of brush	Brush fitting tube insert has damage	Replace brush assembly
Oil leaking out around	Manifold not threaded in tightly	Torque manifold to 110 inch LBS
Oil leaking out around sleeve nut	Tubing not inserted into ferrule far enough	Cut tubing straight, using tubing cutter. Install sleeve nut, install ferrule, stick tubing into manifold, slide ferrule and sleeve nut down and tighten. Tubing to stick out 1/4" beyond ferrule.
Pump pushes oil back up into reservoir	Internal ball check has debris stopping the check ball from	Call LubeMinder Technical for cleaning method
Oil leaking out around brass plunger	O-Ring old and brittle or damaged	Call LubeMinder Technical for disassembly instructions
One brush out of multiple brushes is not lubricating	One-way valve dirty or has chaf in it	Remove manifold, apply light compressed air to blow out chaf Replace One-Way Valve
Oil reservoir continually has chaf pulled in	Tank fill needs strainer	Call LubeMinder Technical to purchase a fill cap strainer
Too much oil coming out of brushes	1) Brass plunger adjustment is out too far 2) Oil will follow path of least resistance, short lines will provide more oil than longer lines.	1) Thread brass plunger in (clockwise) reducing oil to brushes 2) Install orifices into shorter lines, to restrict flow, allowing extra flow to go to longer distance lines.

LUBEMINDER TROUBLESHOOTING GUIDE

SYMPTOM	CAUSE	SOLUTION
Oil is free flowing through tubing when pump is deactivated	One-way valve (Schrader Valve) loose	Tighten one-way valve 1/4 to 1/2 turn
Tubing blows out of manifold	1) Tubing not pushed into ferrule far enough 2) No restrictor in hydraulic pressure inlet fitting	1) If ferrule is damaged or not installed properly, cut off 1/4" of tubing with ferrule, install new sleeve nut and ferrule. Tubing to stick out 1/4" beyond ferrule. 2) Restrictor in fitting at hydraulic pressure inlet was removed or didn't come with kit. Hydraulic system produces more than 2000 PSI causing excess pressure in tubing going to brushes.
Tubing bursting	No restrictor in hydraulic pressure inlet fitting	Restrictor in fitting at hydraulic pressure inlet was removed or didn't come with kit. Hydraulic system produces more than 2000 PSI causing excess pressure in tubing going to brushes.
Tubing blows out of brush	1) Brush fitting tube insert has damage 2) No restrictor in hydraulic pressure inlet fitting	1) Replace brush assembly 2) Restrictor in fitting at hydraulic pressure inlet was removed or didn't come with kit. Hydraulic system produces more than 2000 PSI causing excess pressure in tubing going to brushes.
Oil being pulled back through 5/32 tubing when pump is de-energized	One-way valve (Schrader Valve) seal damaged	One-way valve seal may be old and brittle causing oil to seep around valve, allowing oil to come back into pump. Replace one-way valve.

