

System Instruction Manual

LSC Centralized Lubrication System



LEP **LRMP** **LRBP** **LIMP** **LIBP**

Navigation

System Overview	2
System Structure and Working Principle	3 – 4
Technical Parameter	5 – 6
Overall Dimensions	7 – 8
Installation Instructions	9
Operation of Filling Equipment	10
System Commissioning/Maintenance and Servicing	11 – 13
Fault Analysis and Elimination	14
Transport and Storage	14
After Sales Service	14
Order Information	15 – 20

System Overview

LSC Progressive series centralized lubrication systems have been widely used in industries like wind power, mining, metallurgy, machine tools, textiles, food, ports, commercial vehicles, construction machinery, and heavy mechanical equipment, etc.

The system supplies grease to all necessary lubrication parts as required through a complete grease supply system. It can reduce the friction resistance, reduce contact wear and decrease the friction surface temperature. Meanwhile, it plays a supporting role of anti-rust, shock absorption and sealing.

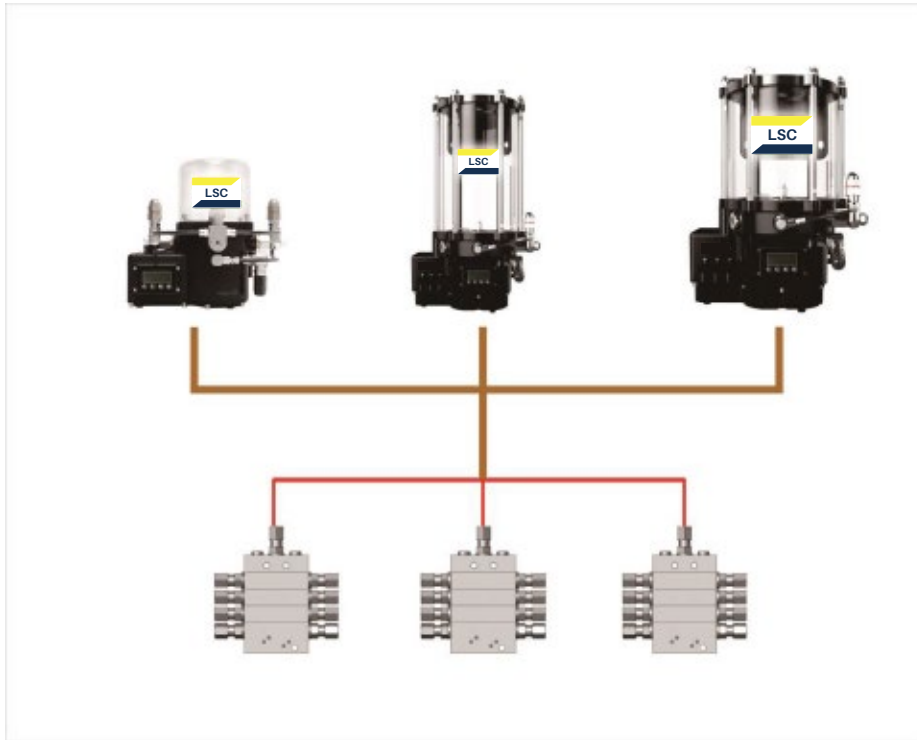

Layout of Progressive System

Product	Function Principle	Grease Thickness till	Metering Quantity per Pump Element	Reservoir	Operating Max. Pressure	Operating Max. Pressure	Power Supply	Max. Pump Elements
			ml/Min		Liter	in bar		
LEP	Piston Pump/Paddle Mode	Up to 2	1.5-4.5	1-2	350 bar	5075	12/24 V DC 220V AC	3
LRMP	Piston Pump/Paddle Mode	Up to 2	1.5-4.5	2-8	350 bar	5075	12/24 V DC 220V AC	3
LRBP	Piston Pump/Paddle Mode	Up to 2	1.5-4.5	4-20	350 bar	5075	12/24 V DC 220V AC	4
LIMP	Piston Pump/Spring Mode	Up to 2	1.5-4.5	2-8	350 bar	5075	12/24 V DC 220V AC	3
LIBP	Piston Pump/Spring Mode	Up to 2	1.5-4.5	4-20	350 bar	5075	12/24 V DC 220V AC	4

System Structure and Working Principle

LSC Progressive series centralized lubrication system is connected to all levels of the dispenser in sequence using the lubrication pump by alternately supplying the grease to each lubrication point. A Sensor is provided on the dispenser to monitor the operating status of the entire system and control the grease amount by operating time.

The system can also be equipped with a pressure gauge between the lubrication pump and the dispenser to give a early warning of fault.

System Composition

The system is composed of lubrication pump, monitor, progressive distributor, sensor (optional), grease hose and accessories.

Working Principle

Operate according to the preset program until the end of stop countdown. Start the lubrication pump, the grease under pressure will be transported to the dispenser through the main lubrication hose. Then the dispenser will deliver the grease to each lube point.

The sensor of the dispenser will detect the grease supply amount of the system in real time and send it back to the monitor. When the filling amount reaches the preset valve, the lubrication pump stops working. The count on the monitor increase by 1, the entire grease supply process of the system ends, and it enters to the next working cycle.

Lubrication Pump

Stirring Plate Mode

Stirring plate mode lubrication pump:
LEP/LRMP/LRBP

Stirring plate is installed in the grease reservoir. When the motor is running, the grease is cut by the stirring plate and moves down under gravity to feed to the suction nozzle of plunger pump through the scraper.

1. Monitor
2. Power Input Connector
3. Alarm Output Connector
4. Sensor Input Connector
5. Reservoir
6. Grease Return Port (only with returnable Safety Valve)
7. Stirring Plate
8. Safety Valve
9. Grease Outlet Port

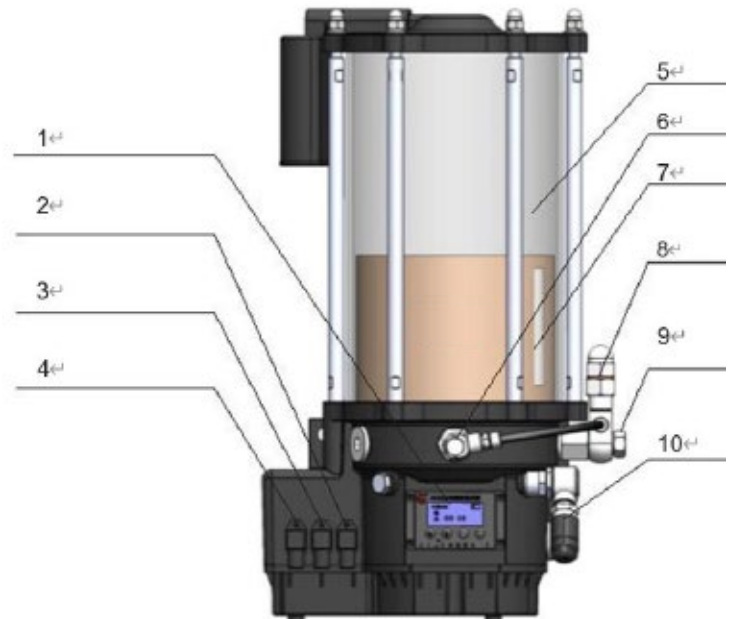

System Structure and Working Principle

Spring Mode

Stirring plate mode lubrication pump: **LIMP/LIBP**

Spring Mode pump is provided within the grease reservoir. Under action of spring, the piston compresses and delivers the grease to the suction of the plunger pump.

1. Power Input Connector
2. Alarm Output Connector
3. Sensor Input Connector
4. Spring
5. Spring Piston
6. Reservoir
7. Grease Return Port (only with returnable Safety Valve)
8. Safety Valve
9. Grease Outlet Port
10. Grease Refilling Nozzle
11. Monitor

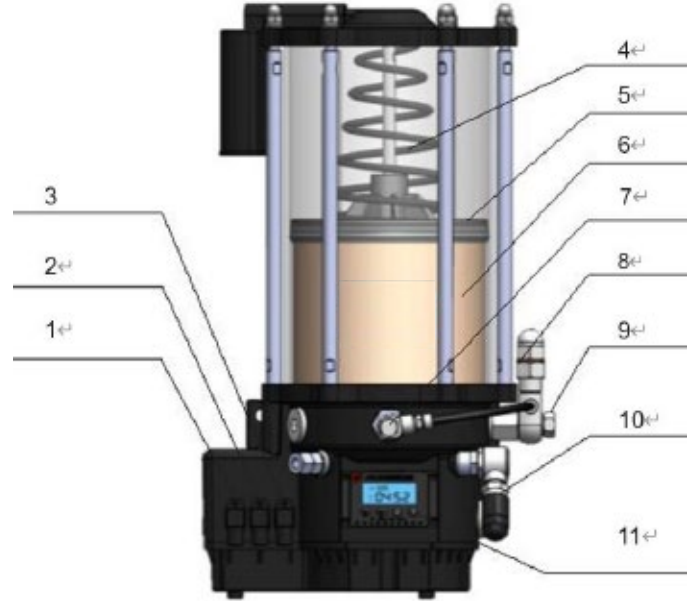

Distributor

The progressive dispenser is actuated in sequence by means of plunger to supply grease to the lubrication point in a progressive way. The built-in indicator rod can be used to observe the running state of the entire dispenser. By installing the sensor, the operation conditions of the entire dispenser can be detected. In the event of blocking, alarm can be triggered. According to the program, multiple outlets can be combined to achieve double volume of one lubrication point.

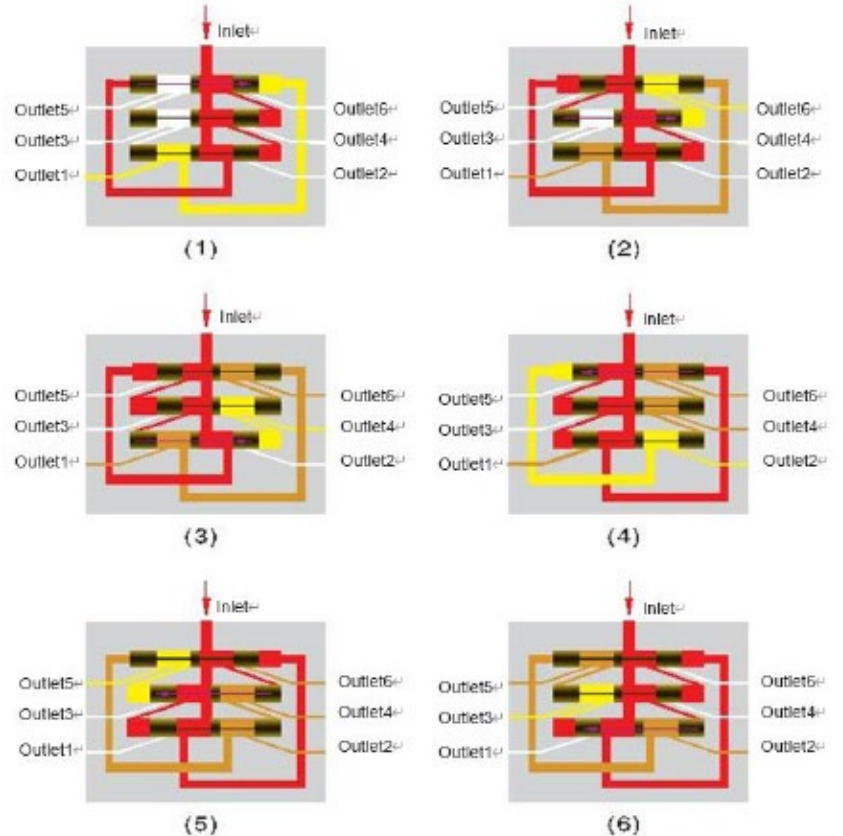

Technical Parameter

Lubrication Pump

	LEP	LRMP	LRBP	LIMP	LIBP
Function principle:	electrically operated piston pump				
Metering quantity Grease:	1.5–4.5 ml/Min				
Working principle:	Stirring Plate	Stirring Plate	Spring	Stirring Plate	Spring
Reservoir Volume:	1/2	2/4/6/8	4/8/10/15/20	2/4/6/8	4/8/10/15/20
Outlets:	1	3	4	3	4
Lubricant:	Grease up to NLGI 2				
Operating Pressure:	350 bar/5075 psi				
Operating Temperature:	-40 to +70 °C				
Protection Class:	IP 65	IP 65	IP 66	IP 65	IP 66
Line Connection:	G1/4				
Electrical Connection:	12 or 24V DC	12 or 24V DC/220V AC	12 or 24V DC/220V AC	12 or 24V DC/220V AC	12 or 24V DC/220V AC
Mounting Position:	Vertical	Vertical/horizontal	Vertical/horizontal	Vertical/horizontal	Vertical/horizontal
Options:	Pressure Sensor/ Main Switch/ Refill Coupling/	Pressure Sensor/ Main Switch/ Refill Coupling/ Grease Level Sensor/Pressure Gauge			

Monitor (Integrated)



Control Mode:	ECU Microcomputer Control
Operating Voltage:	12/24V DC/220V AC
Off Time:	1-30 hours
Operating Mode:	Run according to the preset time
Signal Output:	Grease Level/Fault(due to pressure)

Monitor (External)



Control Mode:	ECU Microcomputer Control
Operating Voltage:	12/24V DC/220V AC
Off Time:	1-30 hours
Operating Mode:	Run according to the preset time
Signal Output:	Grease Level/Fault(due to pressure)

Technical Parameter

Distributor (VPKA/VPKB)

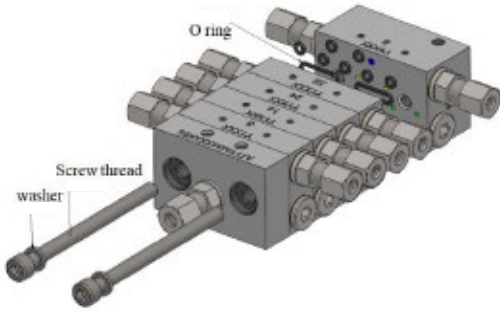

Function principle:	Block metering device
Outlets:	6-18
Lubricant:	Grease up to NLGI 2
Input Pressure:	300 bar
Connection Input:	M10×1
Output Pressure:	200 bar
Connection Output:	M10×1
Start Pressure:	20 bar
Displacement:	0.08 – 1.60ml/cy
Working Temperature:	-25 to +70 °C
Material:	Steel
Surface treatment (Coating):	Zn-Ni plated (free of Cr-VI)

Distributor (SSV/SSVA/SSVD)

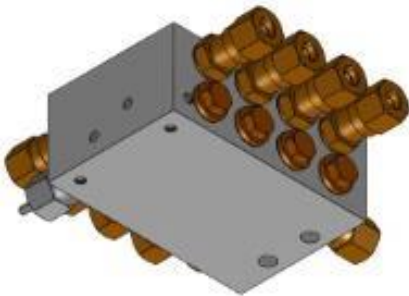

Function principle:	Block metering device
Outlets:	6-20
Lubricant:	Grease up to NLGI 2
Input Pressure:	350 bar
Connection Input:	M10×1
Output Pressure:	200 bar
Connection Output:	M10×1
Start Pressure:	20 bar
Displacement:	0.2 ml/cy
Working Temperature:	-25 to +70 °C
Material:	Steel
Surface treatment (Coating):	Zn-Ni plated (free of Cr-VI)

Sensor

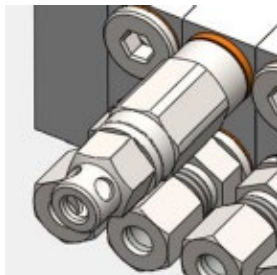

Using the Hall Sensor to detect, and feedback the pulse signal to the monitor. With NPN 3-wire and PNP 3-wire system.

NPN, PNP 3-wire system provides active contacts:



Overall Dimensions

LEP/LRMP/LIMP/LRBP/LIBP

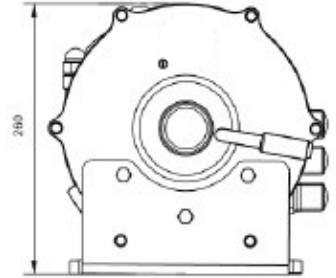
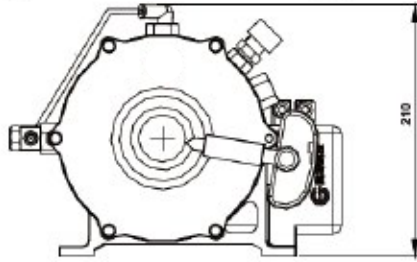
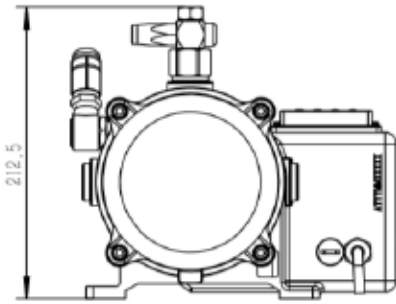
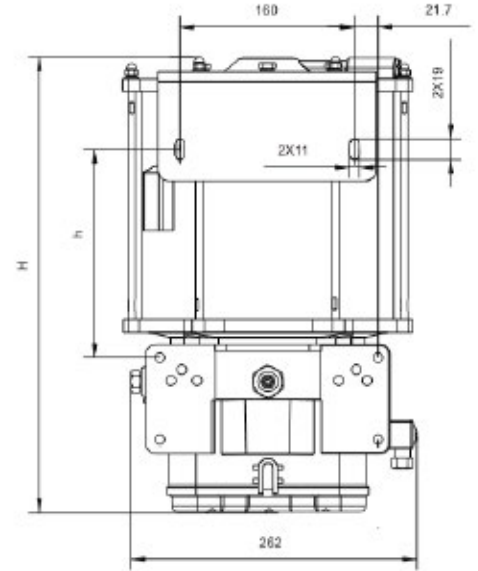
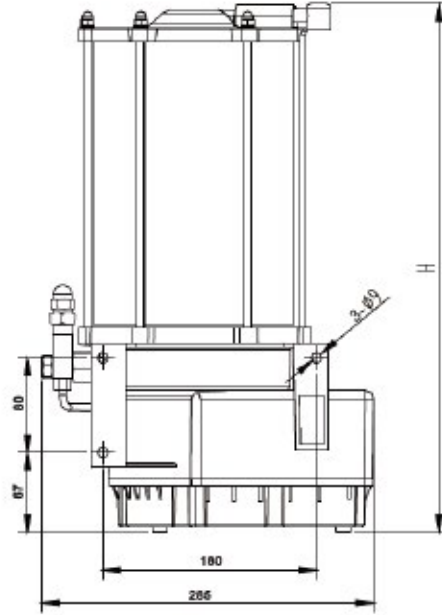
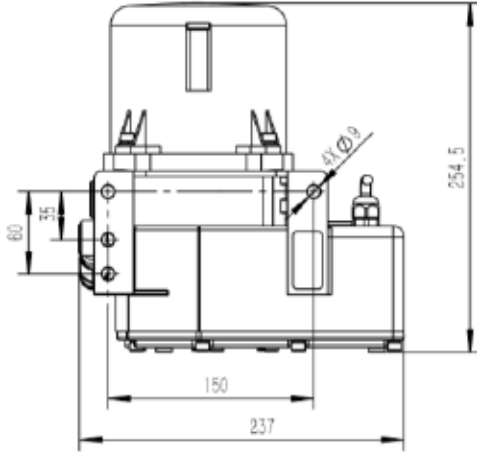

LEP

LRMP/LIMP

LRBP/LIBP

	Reservoir Volume (L)	Width (mm)	Depth (mm)	Height (mm)
LEP	1	237	212	255
	2			378
LRMP/LIMP	2	285	210	385
	4			485
	6			585
	8			685
LRBP/LIBP	4	262	260	418
	8			523
	10			576
	15			771
	20			848

Overall Dimensions

Distributor (SSV/SSVA/SSVD)

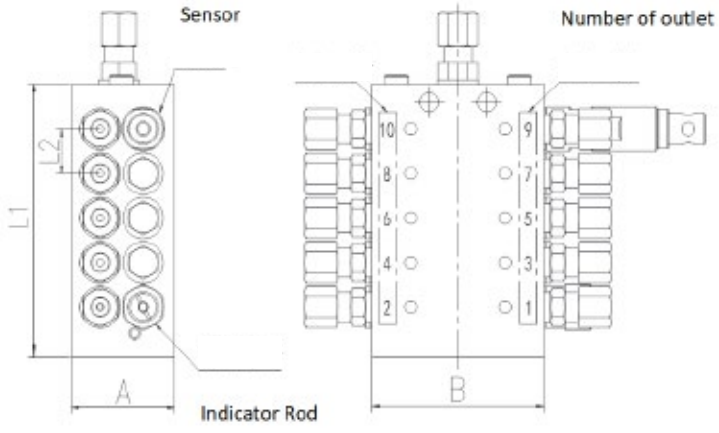

Outlets	A (mm)	B (mm)	L1 (mm)	L2 (mm)	L3 (mm)
6			62		
8			77		
10			92		
12	36	60	107	15	20
14			122		
16			137		
18			152		
20			167		

Distributor (SSV/SSVA/SSVD)

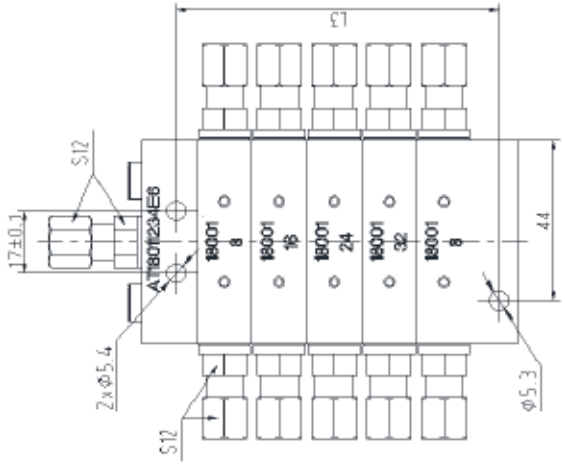

Outlets	Width (mm)	Depth (mm)	L1 (mm)	L2 (mm)	L3 (mm)
6			71		57.2
8			86		72.0
10	56	36	101	15	86.7
12			116		101.5
14			131		116.2
16			146		131.0

Monitor (External)

Height (mm)	Depth (mm)	Width (mm)
44	287.5	78

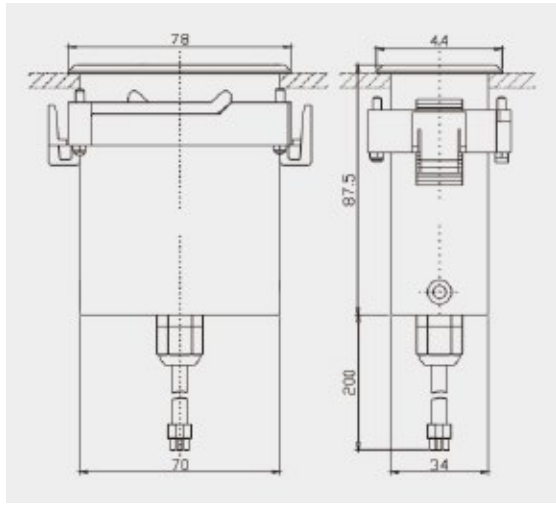

Installation Instructions

Instruction for Installation of Pump

1. It is forbidden to install with the electricity "ON".
2. When installing, make sure that the grease level on the reservoir is clear and clean.
3. The mounting surface should be flat, and the installation connection should be reliable.
4. Distance from heat source should be more than 1 meter.

Instruction for Installation of Distributor

1. Distributors should be installed firmly for convenient maintenance.
2. Keep the inlets and outlets of distributors clean.
3. Distributors should be placed close to lube points; the longest feed line of progressive distributors needs to be less than 25 meters (Note: Varies according to different grease and temperature).

Instruction for Installation of Hoses

1. The grease hoses should be cut vertically in axial direction, the orifice can't be broken or scratched, what's more, the hoses should not be flattened.
2. During installation, the hoses must be kept clean and free of contaminants.
3. Hoses should be short to reduce the system pressure loss, thus ensuring smooth flow.
4. Minimum bending radius of hoses:
 - 7.9*14.3mm resin hose R >100mm
 - 4.0*8.6mm resin hose R >60mm
5. Hose joints must be securely connected without leakage.

Instruction for Pump Reservoir Refilling

1. The position of grease level upper limit label is set according to the product capacity.
2. The lubrication pump must first be exhausted when filling for the first time. The exhaust vent position is set because when filling for the first time, it should exceed the grease level upper limit until reaching the vent position to exhaust. After the air is completely exhausted, the piston will automatically seal the exhaust vent.
3. When refilling later, just fill to the grease level upper limit to prevent grease spill and foreign matter from entering the reservoir.
4. When fill and exhaust for the first time, in order to completely exhaust the air in the reservoir, there will be a small amount of grease overflowing from the exhaust vent, which is within the normal allowable range, just wipe and clean it.
5. If there is air in the reservoir when refilling later, then implement in the same way as filling for the first time to fill the grease to the position of exhaust vent, after the air is completely exhausted, the piston will automatically seal the exhaust vent.

Operation of Refilling Equipment

Operating procedures of grease gun

Thanks to the special transfer coupling for grease gun (manual, pneumatic, electrical), the refilling nozzle of lubrication pump and grease gun can be easily connected with each other for pump refilling.

Before connecting the grease gun and refilling nozzle of lubrication pump, it is necessary to read the instruction for pump reservoir refilling again to make sure no air go into the reservoir during the refilling procedure.



Operating procedures of Grease Refilling Device

By high pressure grease transfer unit including high pressure hoses, connectors and pressure relief valve, the refilling nozzle of lubrication pump and grease refilling devices (manual, pneumatic, electrical) can be easily connected with each other for pump refilling.

Before connecting the grease refilling devices and refilling nozzle of lubrication pump, it is necessary to read the instruction for pump reservoir refilling again to make sure no air go into the reservoir during the refilling procedure.

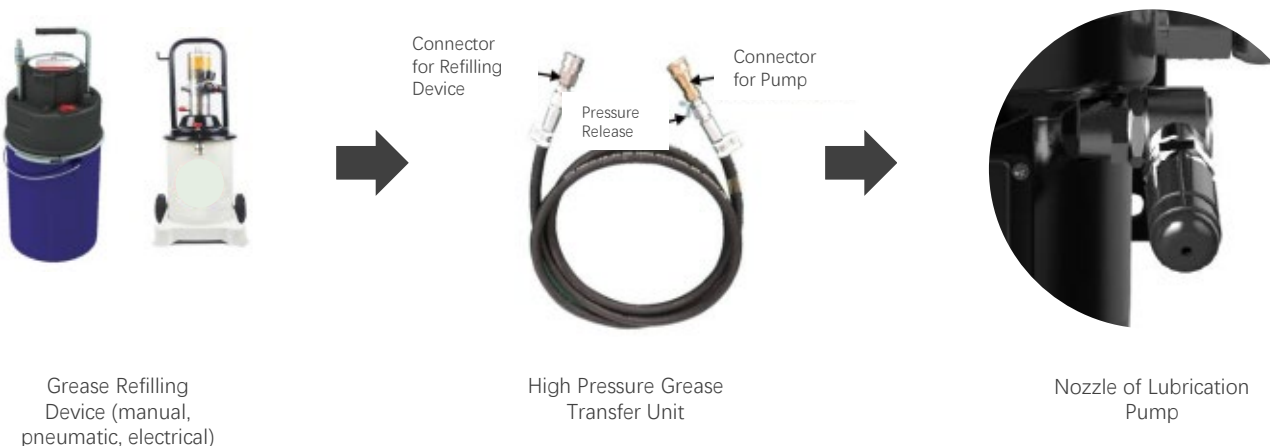

System Commissioning

Before System Running

1. Before connecting the grease pump to the system, run the pump to confirm that it may normally output grease.
2. Run the monitor and set the lubrication interval as demanded.

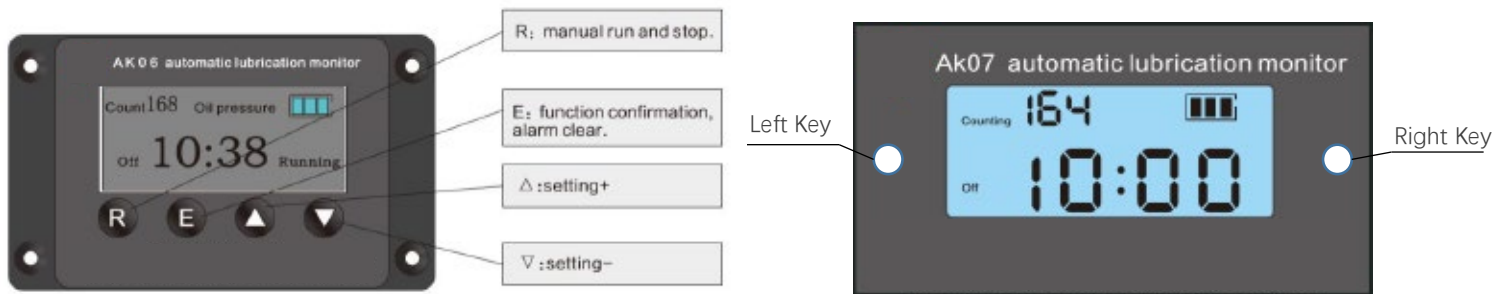

Setting for Integrated Monitor:

By pressing both “▲” and “▼” for 4 seconds and over, press the “E” to enter the setting mode. It will be locked again after the setting mode is exited.

The “E” in turn to select the setting items “1P, 2P, 3P and 4P” to confirm.

- 1P: Click “▲” or “▼” to set the off time (1 to 30 hours, can be customized)
- 2P: Set the number of detection pluses (0-99, can be customized)
- 3P: Click “▲” or “▼” to set the running time (1-60 mins, can be customized)
- 4P: Click “▲” or “▼” to set the low temperature standby value (-50°C to 0°C).

Click “E” to confirm the entering of off status.

Setting for External Monitor:

Explanation of parameters:

- 1P: Off time: 1 to 30 hours
- 2P: Refuel Volume: 0 to 99ml
- 3P: Refuel Route: 1 to 30 mins
- 4P: Low temperature protection: -50°C to 0°C
- 5P: Quantitative accuracy: 1 to 10 (0.1ml – 1.0 ml)

Press and hold the “Right” key and then press the “Left” key. First release the “Right” key and then the “Left” to enter the interface setting 1P. Make setting by clicking the “Left” key. Upon completion of setting, press the “Right” key to switch to the next parameter.

Upon completion of parameter setting, press the “Right” key to save the parameters and return to the “OFF” status.

System Commissioning

Monitor Interface

1 Off status



2 Oil quantity pulse not detected during operation



3 Oil quantity pulse detected during operation



4 Low-temperature standby

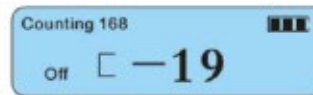

5 Low level early warning status



6 Low level early warning status

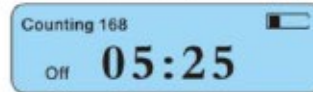

7 Alarm due to lack of grease
(Alarm sends and the machine will be shut down after 6 consecutive operations, the alarm will be automatically acknowledged after the tank is fully filled)

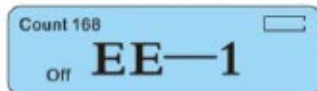

8 Alarm due to insufficient filling
(It has no influence on system operation. Fault will be automatically cleared at the time of next normal operation)



During System Running

1. Press the manual operation key “R” (press the Left key for an external monitor) to make the grease pump work completely. Briefly press again at an interval of every X mins (X=the set value of 3P) after shutdown to make the grease pump operate again until that each lube point discharges grease (Check one by one to confirm normal grease delivery if all the indicator rods are fully extended).

2. If no grease flows out from some lube points, remove their pipelines and observe whether grease may flow out from the distributor outlet. If yes, confirm whether the lubrication pipelines and connector is clogged or leaked. If no, the distributor is faulty. In such case, replace it with a new one and re-start the system until grease may flow out from every lube point.

System Commissioning

After System Running (Maintenance and Servicing)

1. Start manually the grease pump to observe that the monitor is running normally.
2. Check that fresh grease may flow out from all the lube points.
3. Check that the tube bundle is fixed, and wiring harness is connected firm.
4. For maintenance and repair of the lubrication system, replace all the sealing elements such as combination gasket, aluminum gasket, etc.
5. Check that all the pipelines are not damaged or fractured.
6. Check the level of the grease reservoir, refill it if necessary.
7. Make records of maintenance.
8. Maintenance of block type progressive distributor (SSV/SSVA/SSVD): When storage time or stoppage time reaches 6 months, it is necessary to use the same grade grease running dispenser to drain the grease and drain out the internal grease.

The method as follows:

Step 1: Screw out one bolt and washer, start lubrication system to make distributor working. Discharging time should not be less than 1 min. Screw block and washer back as original after finish discharging.

Step 2: Discharge waste grease of another hole as step 1.

Step 3: After 2 holes both finish discharging, start lubrication system and operate at least 2 circles, make sure the distributors work normally.



Step 1

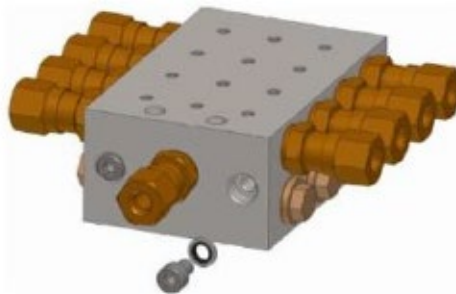

Step 2

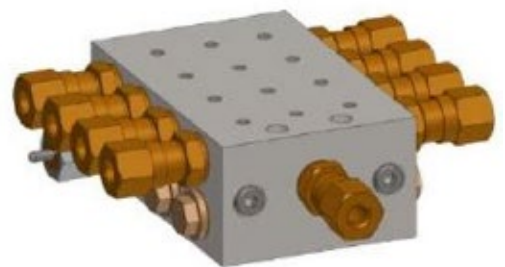

Step 3

Fault Analysis and Elimination

Faults	Reasons	Solution
No Grease comes out from lubrication pump	The motor does not rotate	Test the motor and power supply
	Lubricant is completely pumped out	Exhaust the air
Lubrication pump pressure is insufficient	Plunger pressure is low	Replace plunger
	Safety valve failure	Replace safety valve
Fault code EE-2	System blocked	Check the faulted dispenser and change if necessary
Fault code EE-1	Grease Level insufficient	Fill with grease

Transport and Storage

Transport

During loading/unloading, be careful and avoid upside down.
 During loading/unloading and transportation, avoid collision with other items.

Storage

The products should be stored in a ventilated and dry warehouse free from direct sunlight and without corrosive gas in the air.
 Close all open pipelines to prevent dust and impurities from entering.
 The products should be packed neatly in the warehouse and ensure the ventilation, meanwhile pay attention to the logo on the packing box and avoid upside down. The packing box should keep a distance of at least 100mm from the ground and wall.

After Sales Service

The service network of LSC is worldwide. You can contact us for the information for local LSC Brand or Dealer to get the technology or business support.

sales@lubespec.ca

Order Information– LEP Serie

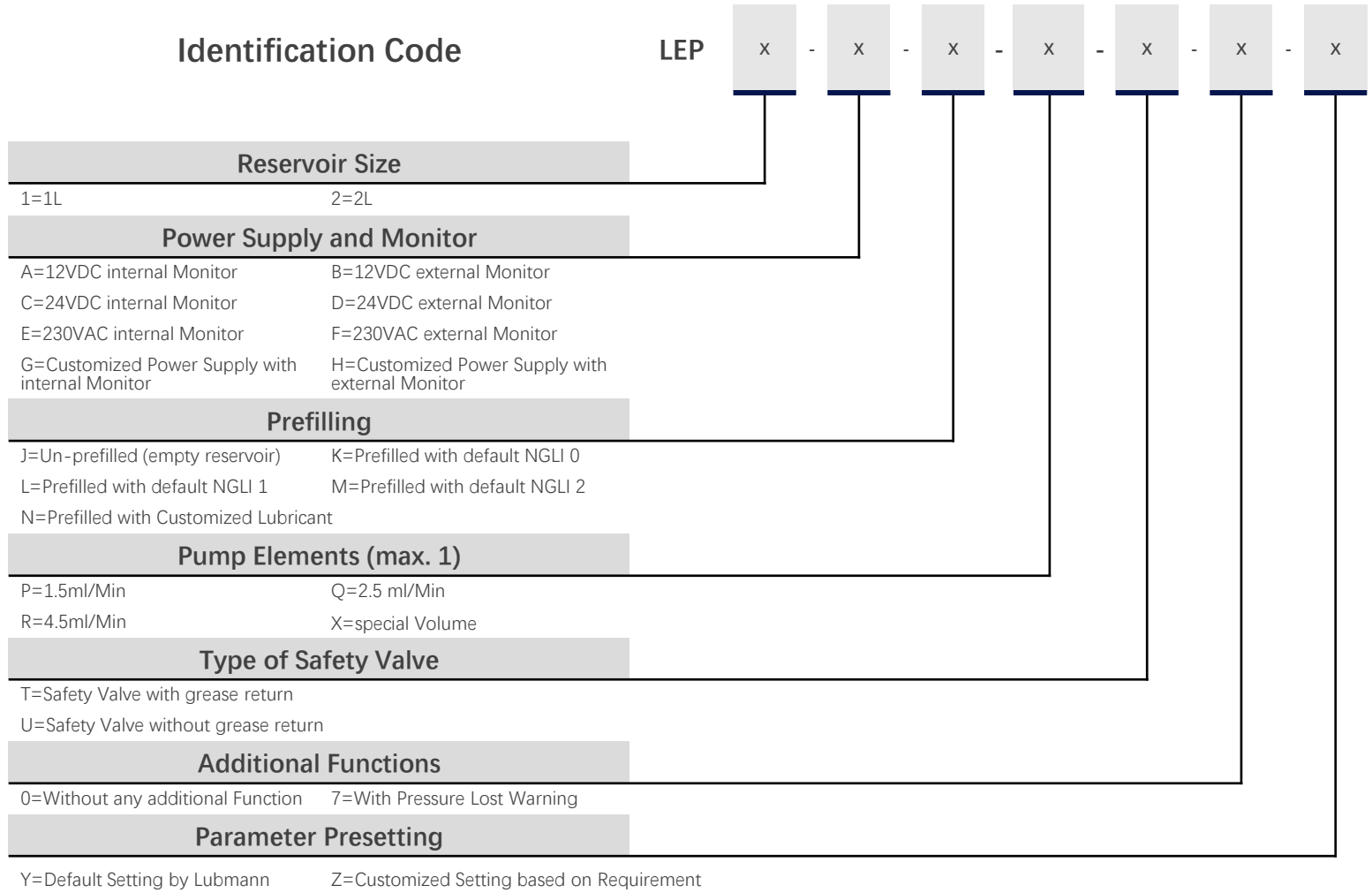

Order Information– LRMP Serie

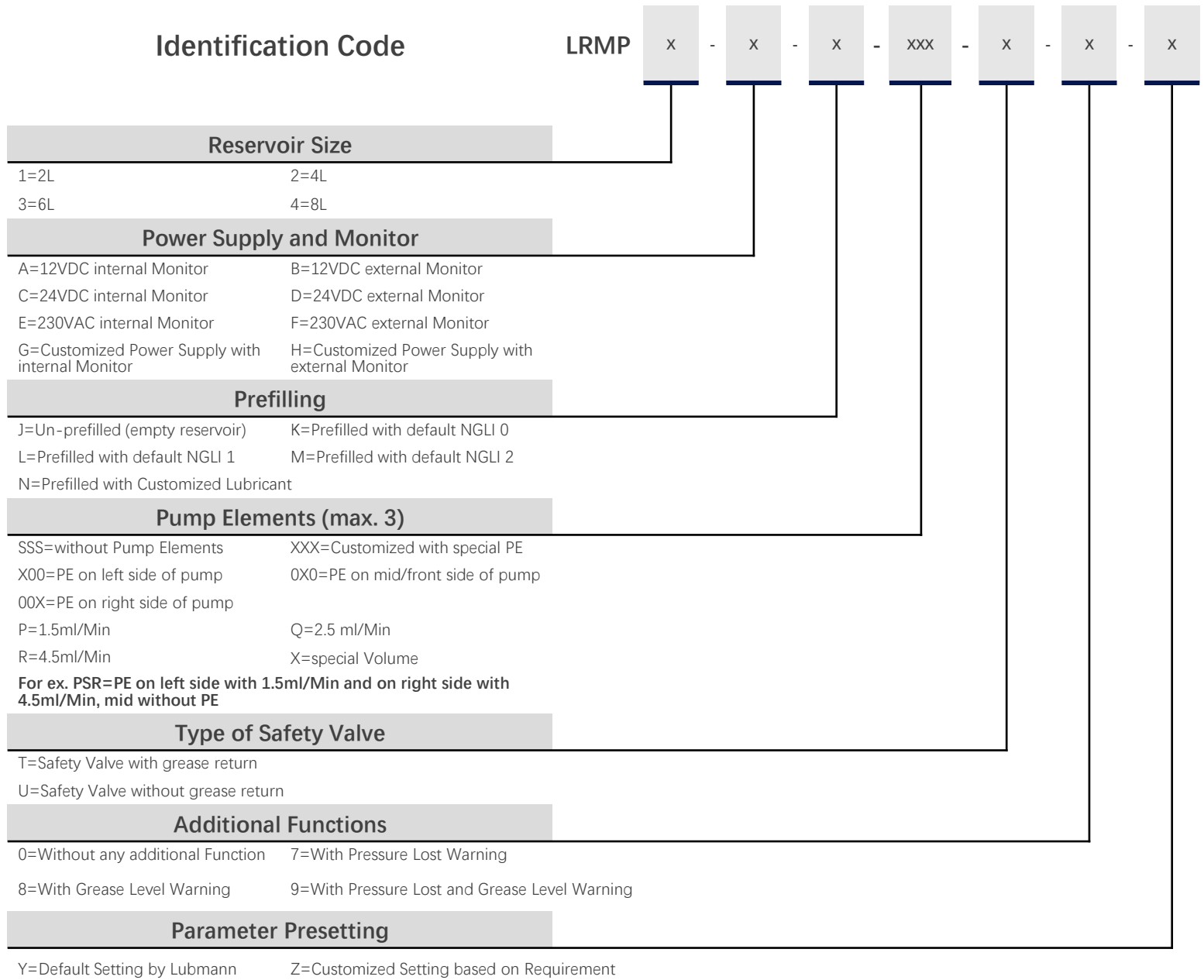

Order Information– LRBP Serie

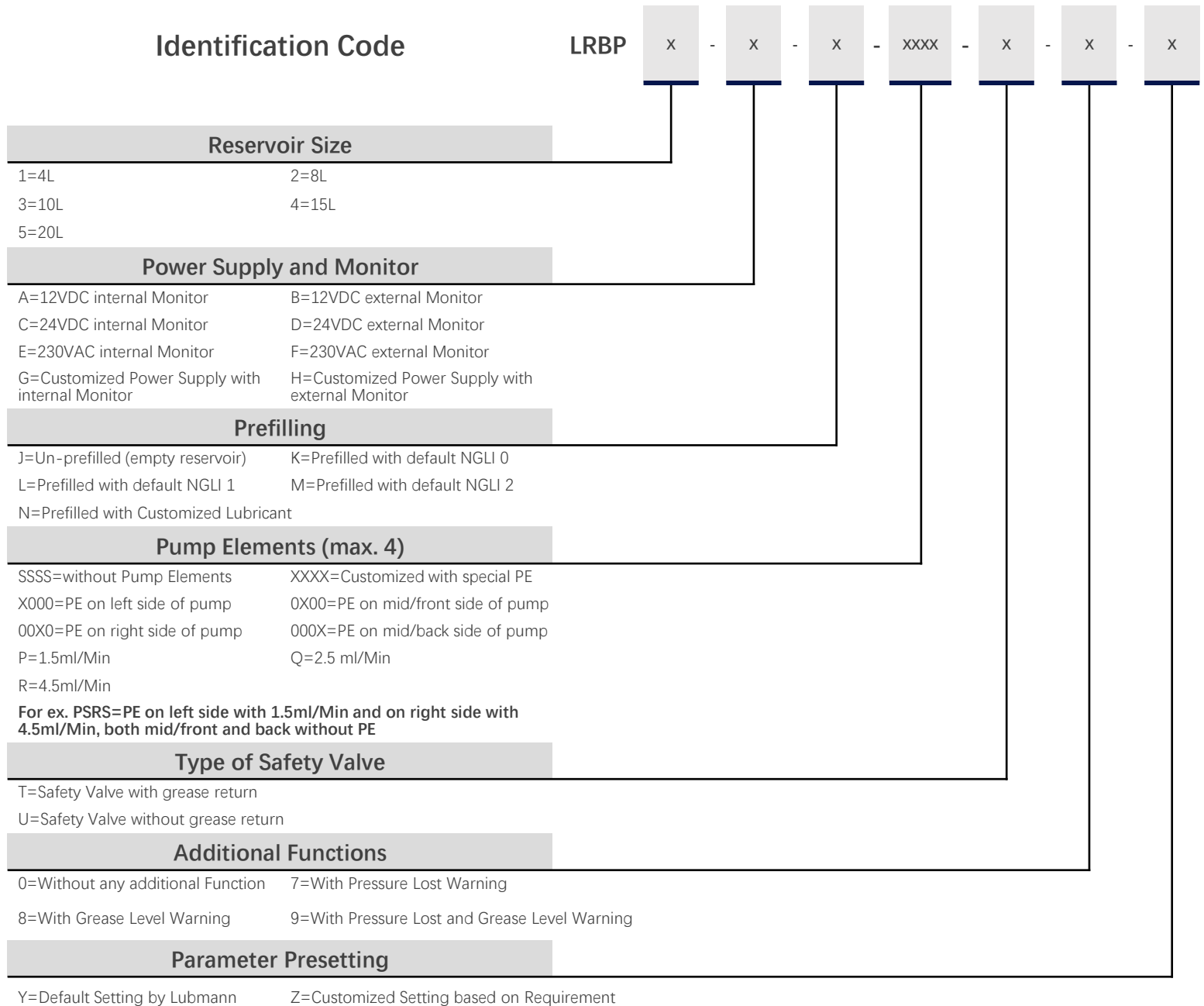

Order Information– LIMP Serie

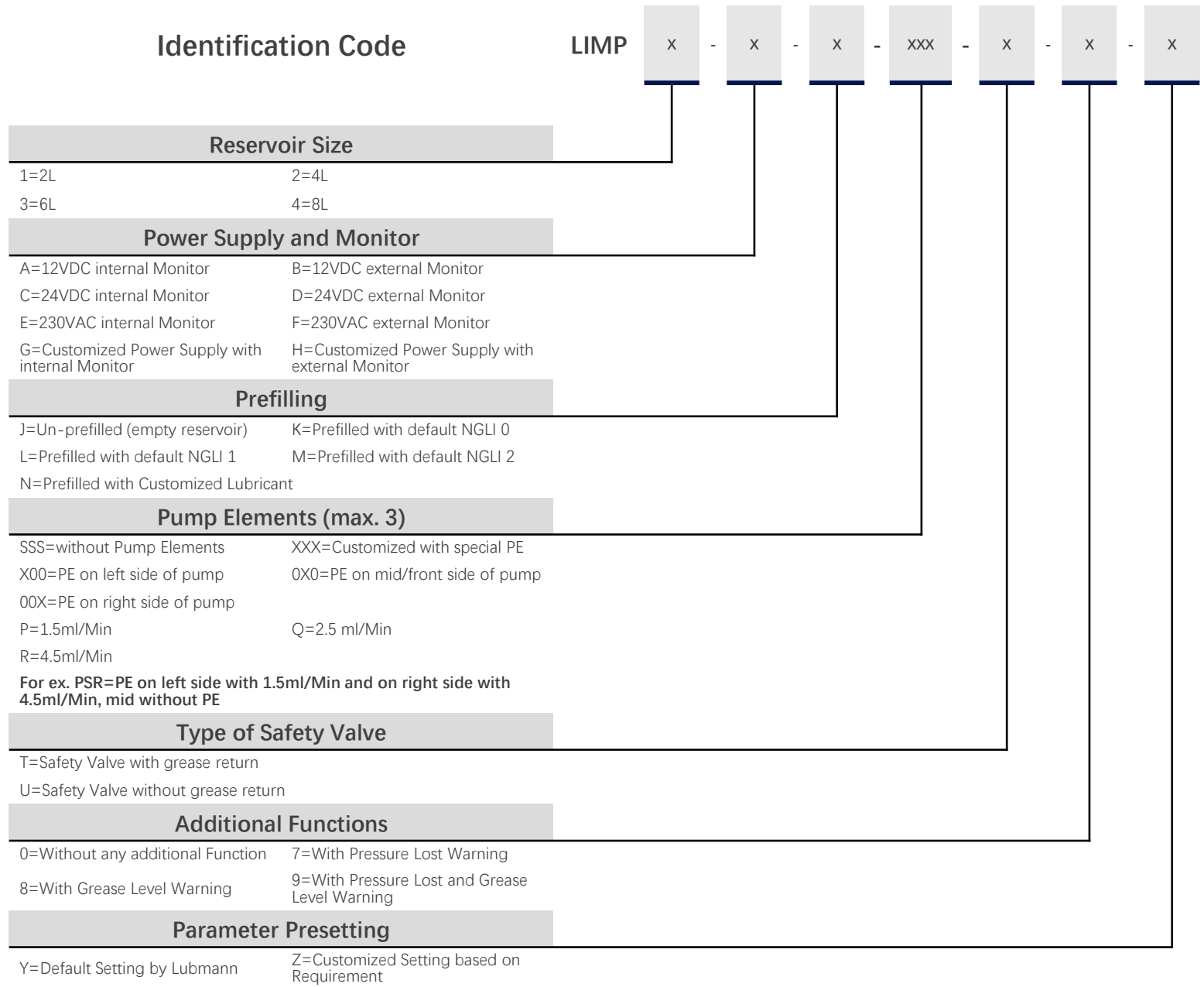

Order Information– LIBP Serie

Identification Code

LIBP



Reservoir Size

- 1=4L
- 2=8L
- 3=10L
- 4=15L
- 5=20L

Power Supply and Monitor

- A=12VDC internal Monitor
- B=12VDC external Monitor
- C=24VDC internal Monitor
- D=24VDC external Monitor
- E=230VAC internal Monitor
- F=230VAC external Monitor
- G=Customized Power Supply with internal Monitor
- H=Customized Power Supply with external Monitor

Prefilling

- J=Un-prefilled (empty reservoir)
- K=Prefilled with default NGLI 0
- L=Prefilled with default NGLI 1
- M=Prefilled with default NGLI 2
- N=Prefilled with Customized Lubricant

Pump Elements (max. 4)

- SSSS=without Pump Elements
- XXXX=Customized with special PE
- X000=PE on left side of pump
- 0X00=PE on mid/front side of pump
- 00X0=PE on right side of pump
- 000X=PE on mid/back side of pump
- P=1.5ml/Min
- Q=2.5 ml/Min
- R=4.5ml/Min

For ex. PSRS=PE on left side with 1.5ml/Min and on right side with 4.5ml/Min, both mid/front and back without PE

Type of Safety Valve

- T=Safety Valve with grease return
- U=Safety Valve without grease return

Additional Functions

- 0=Without any additional Function
- 7=With Pressure Lost Warning
- 8=With Grease Level Warning
- 9=With Pressure Lost and Grease Level Warning

Parameter Presetting

- Y=Default Setting by Lubmann
- Z=Customized Setting based on Requirement

Order Information – Progressive LR VPKA/VPKB

