

# Product Manual

## LSC Single/Multi Point Lubricator



## Overview

Looking for a small cost effective lubricator with large system design built into it you have come to the right place. The ALP-01 is a beast! The motor and pump assembly kicks out over 40 bar of pressure and it has a back up spring loaded diaphragm plate just like the big boys. It can be used as a very robust and reliable single point lubricator or a very robust multi-point lubricator (see Figures 1 and 2 below). The high pressure allows it the flexibility to run many different configurations and the spring loaded diaphragm plate helps improve low temperature pumpability. The unit has been successfully tested in configurations of up to 14 lubrication lines (LSC's blocks can have from 2 to well over 20 outlets if required). The ALP-01 comes with an industry leading two year warranty and powerful 3.6V Lithium Ion battery.



**Figure 1** Single point Lubricator ALP01 connected to single grease point

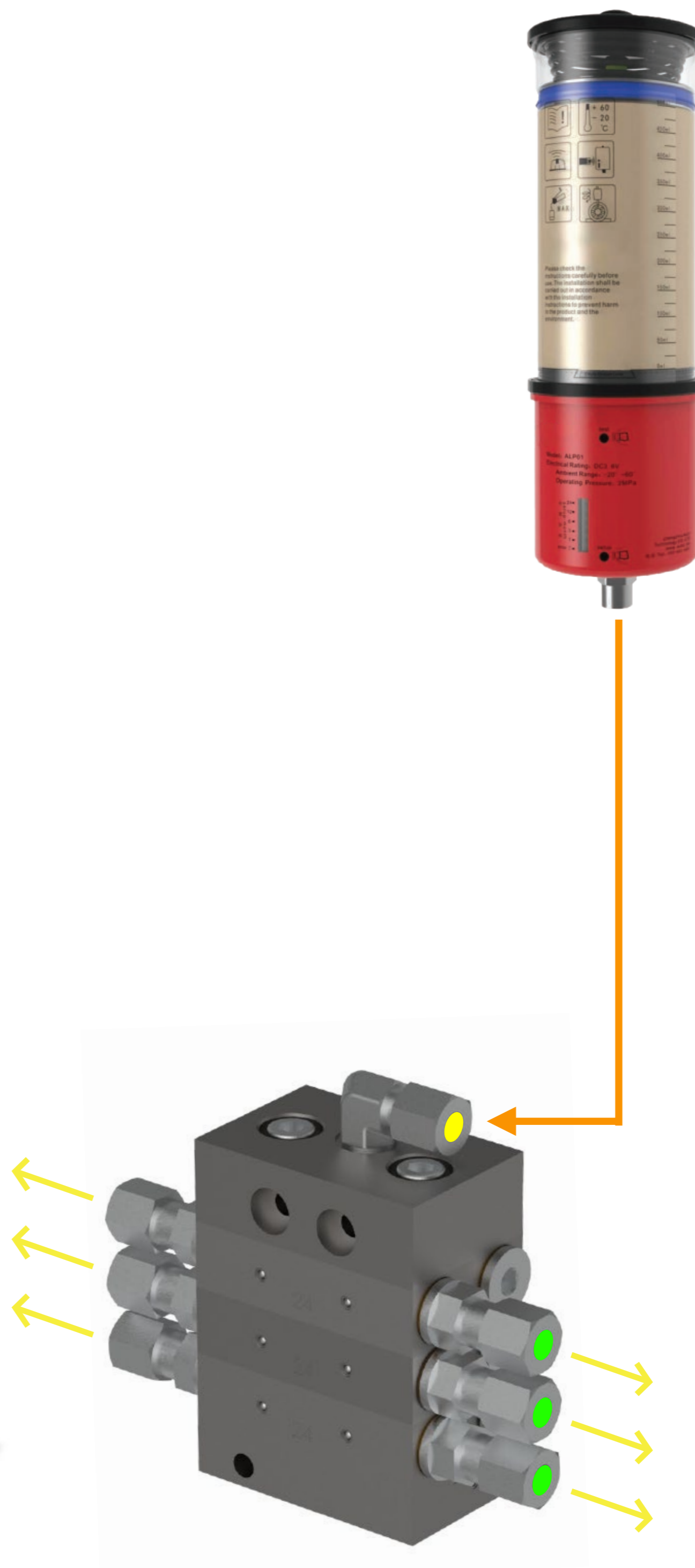

**Figure 2** Single point Lubricator ALP01 connected to a six-point distribution block

## Applications and Industries

- Crushers & Screeners
- Mining
- Wastewater Plants
- HVAC and Fans
- Small Mobile Equipment
- Cement Plants
- Pulp and Paper
- Machine Tools
- Agricultural Equipment
- Wood Processing
- Ski Lifts
- Etc.
- Motors, pumps, gear boxes, etc.
- Metal Processing
- Escalators
- Quarries
- Conveyors
- Food Processing
- Car Washes
- Breweries

## Operations

By using a magnetic cap which sits on top of the grease fitting (see Figure 3 – #1) the lubricator can be turned on and off and the preset running period can be adjusted.

### TECHNICAL DATA:

#### Motor/Battery:

Operating voltage:	3.6 V DC Lithium
Nominal capacity of battery:	2.6 Ah
Maximum continuous current:	100 mA

#### Pump:

Pump type:	Plunger Pump
Max. operating pressure:	40 bar
Permissible operating temperature:	-30°C to +60°C
Standard outlet connector thread:	R 3/8

Reservoir size:	120/250/500 ml
Mounting position:	Vertical/Horizontal
Protection type:	IP65 as per ISO
Max volume of refilled grease: (Lifetime of the Single Point Lubricator)	5000 ml
Preset operation period:	1 - 24 Months

#### Controller:

Type of controller:	Built-in Controller
Display mode:	LED Indicator Display

Lubricant:	Greases up to NLGI-CI.2
Grease refilling:	From Top under Magnetic Cap



**Figure 3** ALP01 Single Point Lubricator Functional Components

- 1) Magnetic Cap
- 2) Reservoir with Spring Loaded Diaphragm
- 3) Lubricator Body
- 4) Lithium Battery Cell
- 5) Activating Zone - Test
- 6) Preset Indicator
- 7) Activating Zone - Preset Operation Period
- 8) Outlet Connector - R 3/8"

## Operation - Grease Filling and Refilling

1. Take off the magnetic cap (Figure 3 – #1)
2. Connect the manual/electrical grease pump to the grease nipple under the magnetic cap (Figure 4).
3. Fill the grease into the reservoir smoothly until the “MAX. Grease Level”\* (Figure 5) is reached.
4. Disconnect the grease pump and grease nipple and clean the grease nipple. Put the magnetic cap back on top of the grease nipple.

*\* Attention: please slow down the grease injection speed when the grease level in the reservoir almost reaches “MAX” to avoid over-filling (the grease level can not be higher than the ventilation hole (Figure 6)).*

During the initial grease fill air bubbles may form in the reservoir. To purge the air bubbles the level of the grease needs to be 1-2mm higher than the ventilation hole. This will help the air bubbles escape the reservoir (see Figure 6).

Start a test greasing cycle to check that the lubricant comes out from the lubricator outlet. Make sure there are no air bubbles mixed in the lubricant. Otherwise, continue to use the test greasing cycle until all air bubbles are eliminated.

*\* Too many air bubbles may damage the unit.*

Please make sure the grease level is NOT higher than “MAX. Grease Level” during the regular refilling process.

### Important Tips for Outdoor or Food Grade Applications

In order to achieve a high cleanliness standard, the creation of a grease film is strongly recommended.

1. Get any air bubbles out of the reservoir.
2. Clean the surface around the ventilation hole.
3. Apply a grease film on the ventilation hole (Figure 6).



**Figure 4**  
Grease Nipple Under Magnet Cap

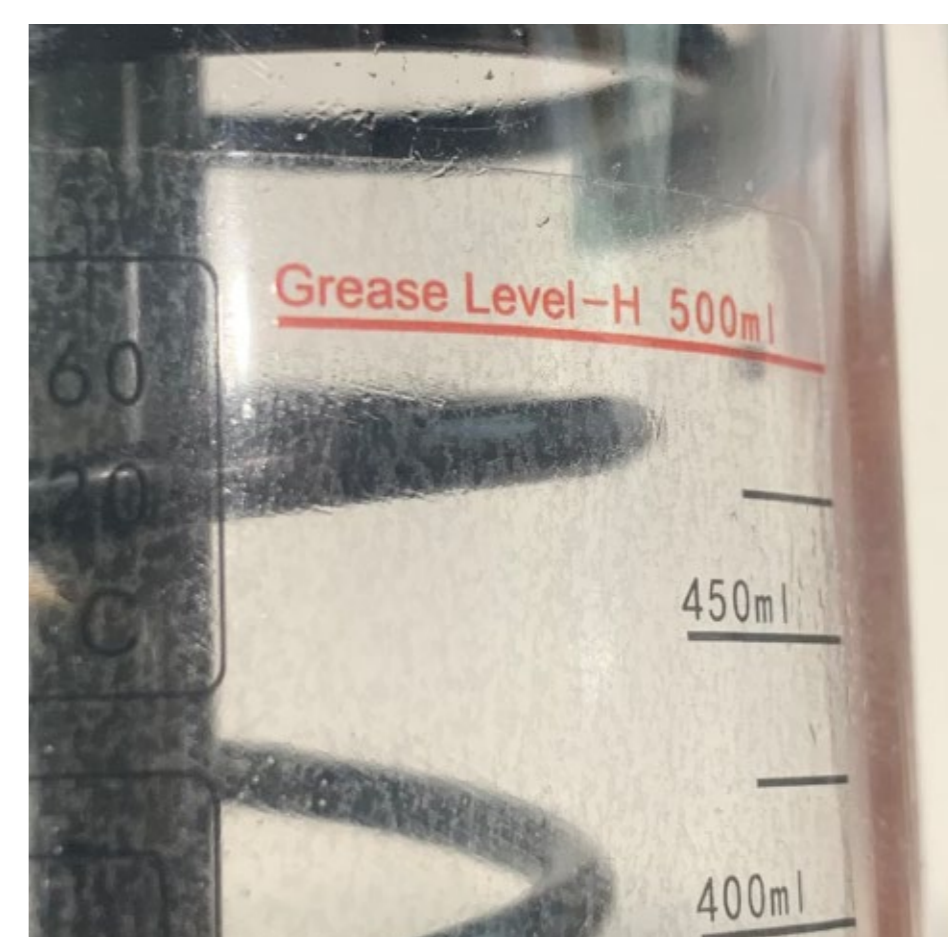

**Figure 5**  
Grease Level

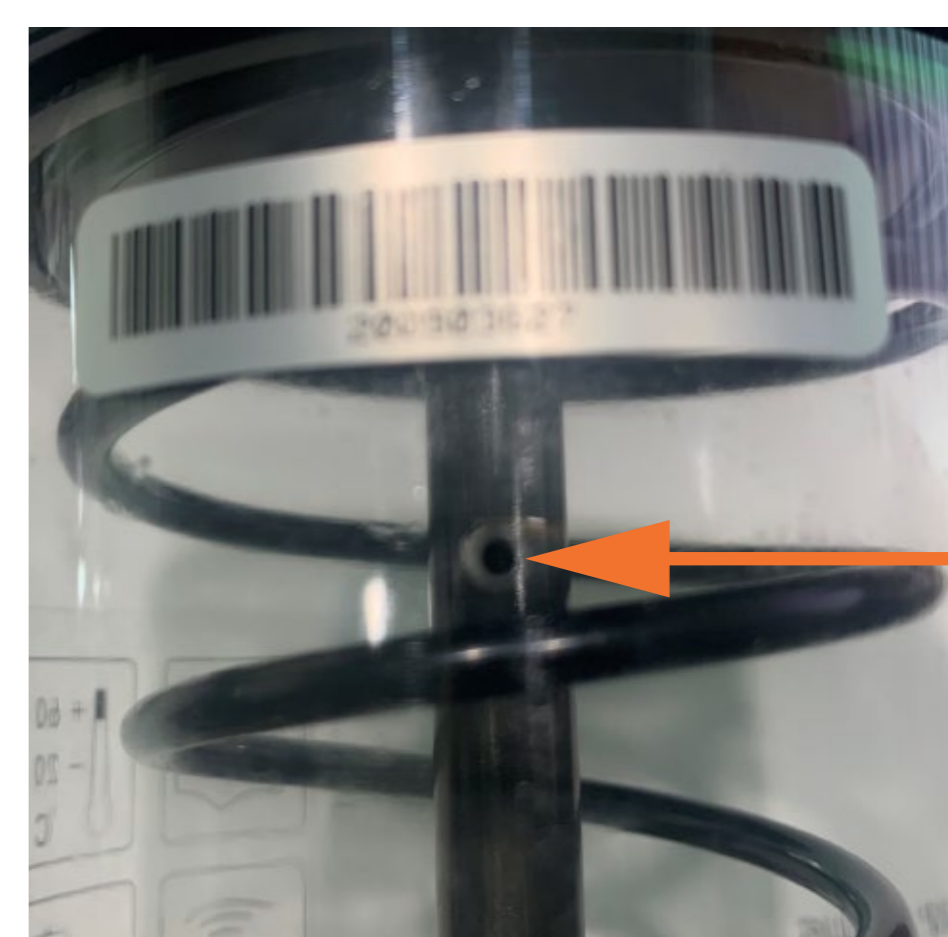

**Figure 6**  
Ventilation Hole

## Operation - Grease Refilling Period

### Preset of the Operation Period (Theoretical Grease Refilling Period )

The preset operation period equals the theoretical grease refilling period, which is set on the single point lubricator ALP01.

Based on the reservoir size the preset operation period can be adjusted on the lubricator (See Figure 7). The grease consumption per month or per week for the greasing point of connected divider can be calculated as per the following table (Table 1).

### Recommended Grease Refilling Period

To make sure the grease can be refilled before the reservoir is empty, a shorter grease refilling period is recommended (around 80% of the theoretical grease refilling period).



**Figure 7**

Preset Operational Period

- 1) Pad of Preset Operational Period in Months
- 2) LED Indicator Interface

**Table 1**

Preset Operation Period	Grease Refilling Period	Grease Consumption* for 120 mL Reservoir		Grease Consumption* for 250 mL Reservoir		Grease Consumption* for 500 mL Reservoir	
		Per Month	Per Week	Per Month	Per Week	Per Month	Per Week
24 Months	20 Months	5.0 cm <sup>3</sup>	1.1 cm <sup>3</sup>	10.4 cm <sup>3</sup>	2.3 cm <sup>3</sup>	20.8 cm <sup>3</sup>	4.6 cm <sup>3</sup>
12 Months	10 Months	10.0 cm <sup>3</sup>	2.3 cm <sup>3</sup>	20.8 cm <sup>3</sup>	4.6 cm <sup>3</sup>	41.7 cm <sup>3</sup>	9.3 cm <sup>3</sup>
6 Months	5 Months	20.0 cm <sup>3</sup>	4.6 cm <sup>3</sup>	41.7 cm <sup>3</sup>	9.3 cm <sup>3</sup>	83.3 cm <sup>3</sup>	18.5 cm <sup>3</sup>
3 Months	10 Weeks	40.0 cm <sup>3</sup>	9.2 cm <sup>3</sup>	83.3 cm <sup>3</sup>	18.5 cm <sup>3</sup>	166.7 cm <sup>3</sup>	55.6 cm <sup>3</sup>
1 Month	24 days	120.0 cm <sup>3</sup>	27.5 cm <sup>3</sup>	250.0 cm <sup>3</sup>	55.6 cm <sup>3</sup>	500.0 cm <sup>3</sup>	111.1 cm <sup>3</sup>

\* The grease consumption volume in the above table is only for a single grease point or the inlet of the divider. For the multi greasing points which connected by divider, depends on the configuration of the divider, which can be checked in our divider manual. Please contact us for further information.

## Operation - Test and Time Setting

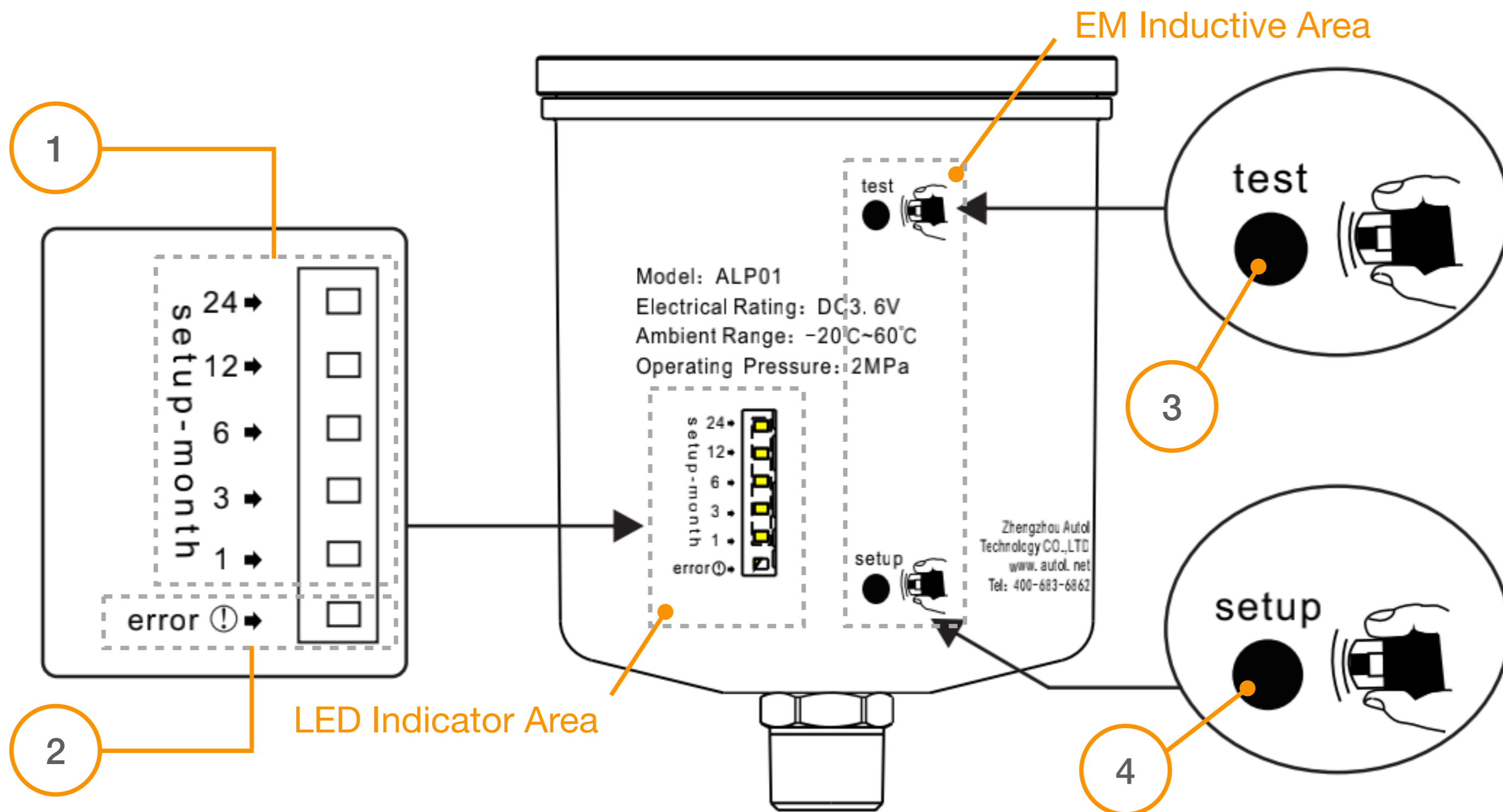

Figure 8 Control Panel of ALP01

### Control Panel of ALP01

The control panel area of ALP01 single point lubricator is made up of the LED indicator area (① and ② in **Figure 8** and the EM inductive area (③ and ④ in **Figure 8**).

**LED Indicator Area:** The LED indicator displays information about the lubricator’s operational period and error codes during the operating process through different display modes such as constant lighting or flashing.

- 1 - Setup - Month:** shows the preset operation period in months in GREEN LED, e.g. 1=1 month, 3 = 3 months, or shows together with error and an error code
- 2 - Error:** shows together with LED of Setup - Month for the error code such as Low Battery or overloading of the lubricator

**EM Induction Area:** Users can contact the EM induction area by using the magnetic cap to adjust the operating period, or to implement a manual greasing cycle.

- 3 - Test : Test induction point for starting a manual greasing cycle
- 4 - Setup: Setup induction point for operation period length adjustment

### First Time Running

When the single point lubricator ALP01 first connects to the battery, all lights in the LED indicator area turn on for 2 seconds, and then turn off. The lubricator default operation period light flashes x times (x depends on the volume of the reservoir\*). Lubricator has been initialized and starts working under the default operation period immediately.

\* For 120 ml reservoir x=1, for 250 ml reservoir x=2, for 500 ml reservoir x=5.

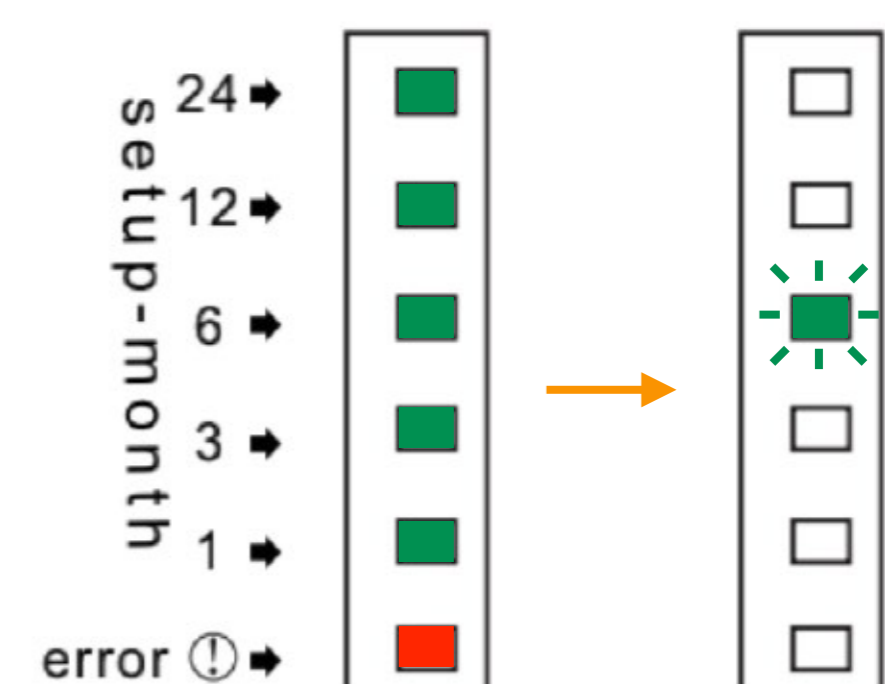

Dia. 7.2 First time running

## Operation - Test and Time Setting

### Operation Period Adjustment

To change the preset operation period:

1. Place the magnetic cap close to the Setup EM induction point to activate the setting mode until the preset/default operation period LED turns on, then move the cap away.
2. Use the magnetic cap close to the induction point again for at least 3 seconds to adjust the length of the operational period.
3. The light jumps to the next value after removing the cap\*.
4. Repeat the step 2 and 3 to choose the required length of the operation period.
5. Move the cap away, let the LED of the required value light for 5 seconds and flash once to save the setting.
6. Put the magnetic cap back on top of the lubricator.  
Adjustment of the operation period length finishes.

\* The jumping sequence is 1 - 3 - 6 - 12 - 24 - 1

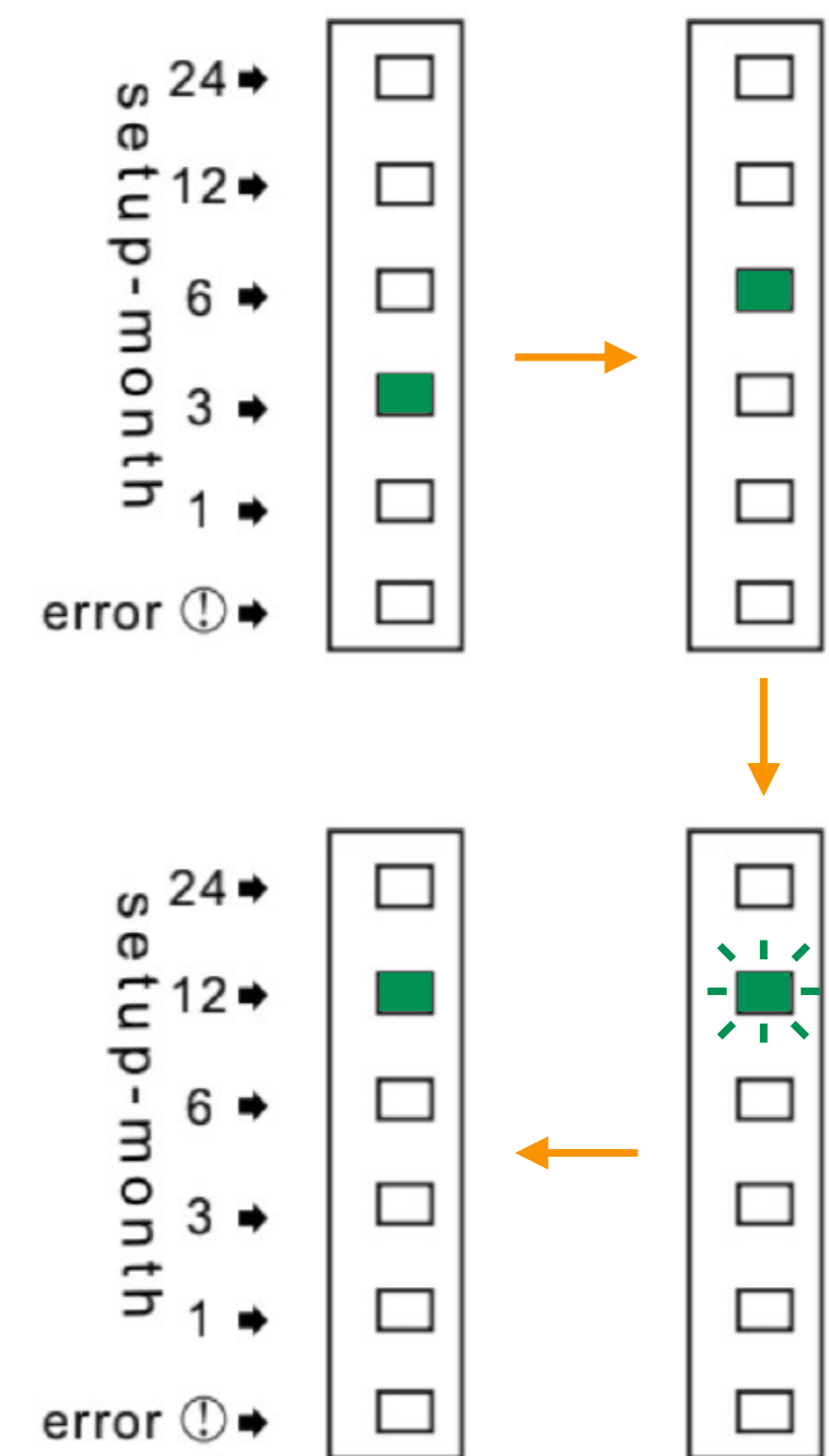

**Dia. 8.1** Adjustment of Operation Period Length

### Test Cycle

Use the magnetic cap close to the Test induction point for at least 3 seconds, then move the cap away. The lubricator immediately starts a manual greasing cycle (fixed running time as around 20 seconds and the total greasing volume around 0.6cm ).

During the running time, use the magnetic cap to close the test induction point to immediately stop the cycle.

During the test cycle running time, the LED for corresponding setting of the operation period will continue to flash until the running cycle ends.

**Recommended:** After the lubricator has been long inactive or the battery is replaced, start a test greasing cycle to ensure that the lubricator works and confirm the current setting of the operating period.

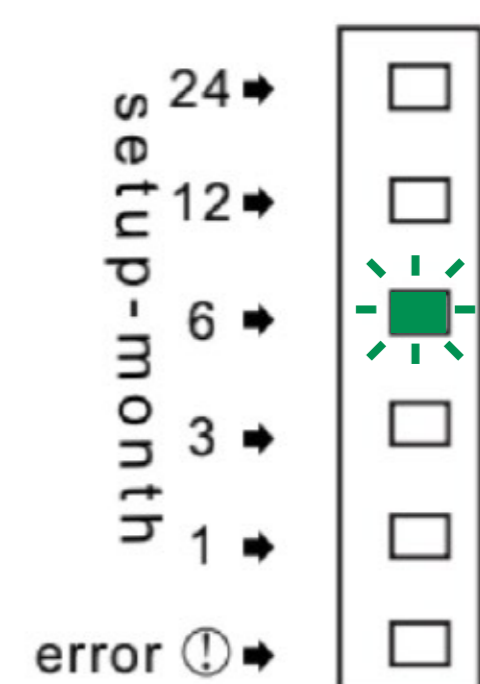

**Dia. 8.2** Test Greasing Cycle

### Idle Operation

To avoid mis-operation of the lubricator, a function of stopping the lubricator is not available in the standard version. Please contact us if you have such a requirement.